

# MASTER PLAN WB&A TRAIL

*South Shore*

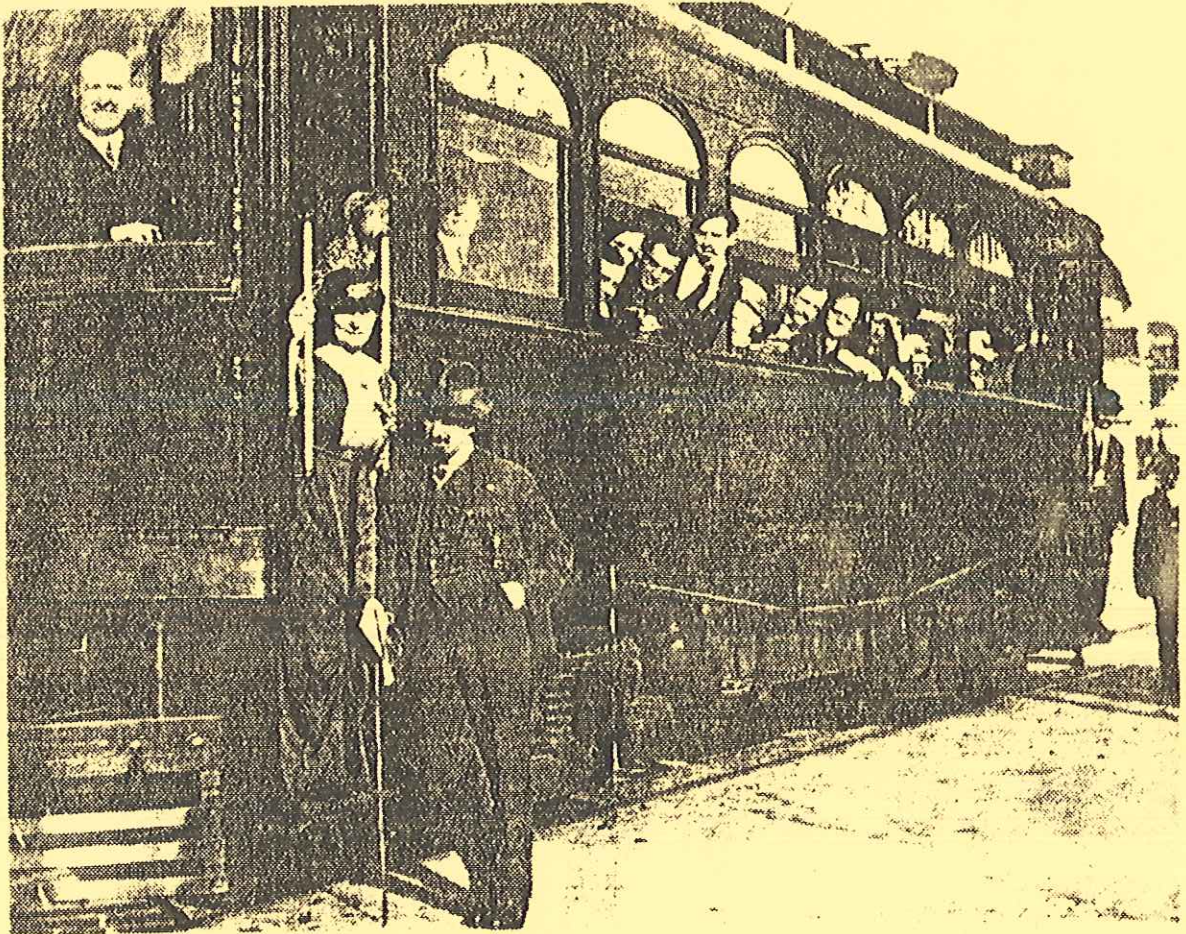

FROM BESTGATE RD. TO DICUS MILL RD.  
ANNE ARUNDEL COUNTY, MD.

WB&A HIKING/BIKING TRAIL  
MASTER PLAN

Prepared for Anne Arundel County, MD

James Lighthizer, County Executive  
Joseph McCann, Director, Department of Recreation & Parks  
Parker Andrews, Director, Department of Public Works

Prepared by:

HUMAN & ROHDE, INC.  
Landscape Architects/Land Planners  
Towson, MD

June 30, 1989

**Human & Rohde, Inc.**  
landscape architects/land planners

JOHN C. ROHDE, ASLA  
SALLY MALENA, ASLA

110 E. PENNSYLVANIA AVE.  
TOWSON, MARYLAND 21284  
(301) 825-3885

June 30, 1989

Mr. Joseph McCann  
Director  
Recreation & Parks Department  
Arundel Center  
Annapolis, MD 21401

RE: WB&A Hiking/Biking Trail

Dear Mr. McCann:

We are pleased to submit the master plan for the WB&A Trail.

The master plan incorporates the planning effort of our office, your staff, and the other County agencies involved in the development of this County facility.

It has been a pleasure working on this project and our staff would like to thank you for the opportunity to assist the County in the planning of the WB&A Trail.

We hope this master plan will assist you and the Department of Public Works in providing for the future development of the WB&A Trail.

Sincerely,

HUMAN & ROHDE, INC.

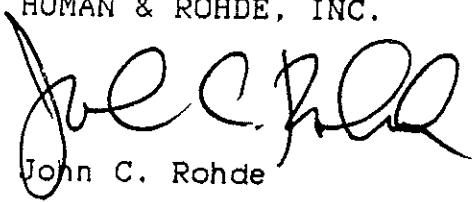

John C. Rohde

JCR/jms

TABLE OF CONTENTS

INTRODUCTION . . . . . 1

OVERALL SETTING . . . . . 2

HISTORY . . . . . 3

EXISTING CONDITIONS . . . . . 7

    A. Right of Way, Property Ownership. . . . . 8

    B. Topography . . . . . 8

    C. Vegetation Observed . . . . . 9

    D. Utilities . . . . . 10

    E. Road Crossing . . . . . 10

    F. Drainage . . . . . 12

    G. Soils . . . . . 12

ANALYSIS . . . . . 13

PROPOSED TRAIL ALIGNMENT . . . . . 15

DEVELOPMENT IMPACT, APPROVALS & PERMITS . . . . . 16

TECHNICAL & DESIGN CONSIDERATIONS . . . . . 17

ADMINISTRATION OF THE TRAIL . . . . . 29

PROJECT PHASING . . . . . 31

COST ESTIMATE . . . . . 32

BIBLIOGRAPHY

---

## INTRODUCTION

---

A hiker/biker trail is a linear park. In addition to providing access to and between county parks, a trail can also be a recreational experience. The WB&A Trail can be such a linear park. It can be a ribbon of green open space within the developing areas of Anne Arundel County.

A few trails exist in communities adjacent to Anne Arundel County. The C&O Canal National Historical Park is a famous example. There is a need for trail development in Anne Arundel County.

The County has the opportunity to develop a similar trail system on the track bed of historic railroads that operated lines between Annapolis and Baltimore, Washington and Baltimore (the mainline) and a line from Annapolis to a junction on the Washington/Baltimore line. The WB&A trail is one segment of the trail system.

Much of the proposed WB&A trail runs through natural environments and low density residential areas. The trail travels by communities and activity areas such as the Eisenhower Golf Course. The WB&A trail will be an ideal linear park, one that can satisfy daily users (i.e. school children) and recreational users, people enjoying the trail as a weekend recreational experience.

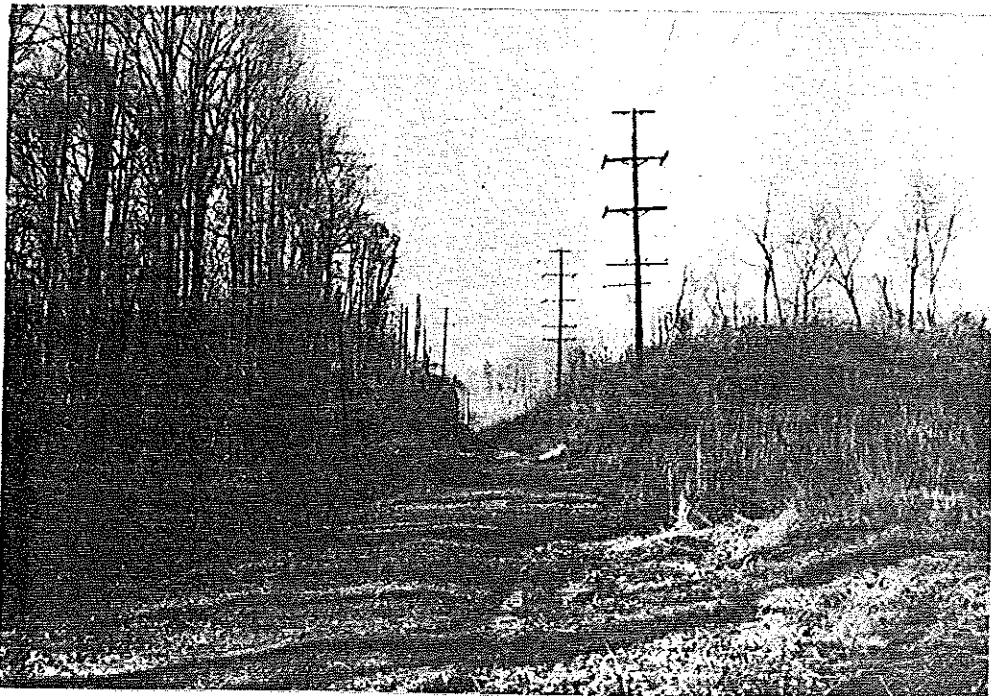

WB&A Bed Between Rt. 178 and Fairfield Loop

---

## OVERALL SETTING

---

The WB&A trail extends along a northwest/southeast corridor in the middle of Anne Arundel County. The southeast terminus is located in the Bestgate/Parole area, just north of the Annapolis Mall. The northwest terminus is located in the area of Odenton/Arundel Acres.

The trail is located in a predominantly low density residential area of the county. It runs adjacent to major open spaces: the Eisenhower Golf Course, the Anne Arundel County Fairgrounds, and the U.S. Naval Academy Dairy Farm. Two elementary schools are also located along the trail: South Shore Elementary School and Millersville Elementary School.

There are some dramatic natural features along the trail. Several overlooks into ravines with Beech/Oak association trees happen along the trail. In addition, the historic track bed has many cut (depressed) areas and fill (elevated) areas.

A few difficult road crossings are located along the trail. Most of these occur at signalized intersections. With appropriate signs for motorists and hikers/bikers, these difficulties can be minimized.

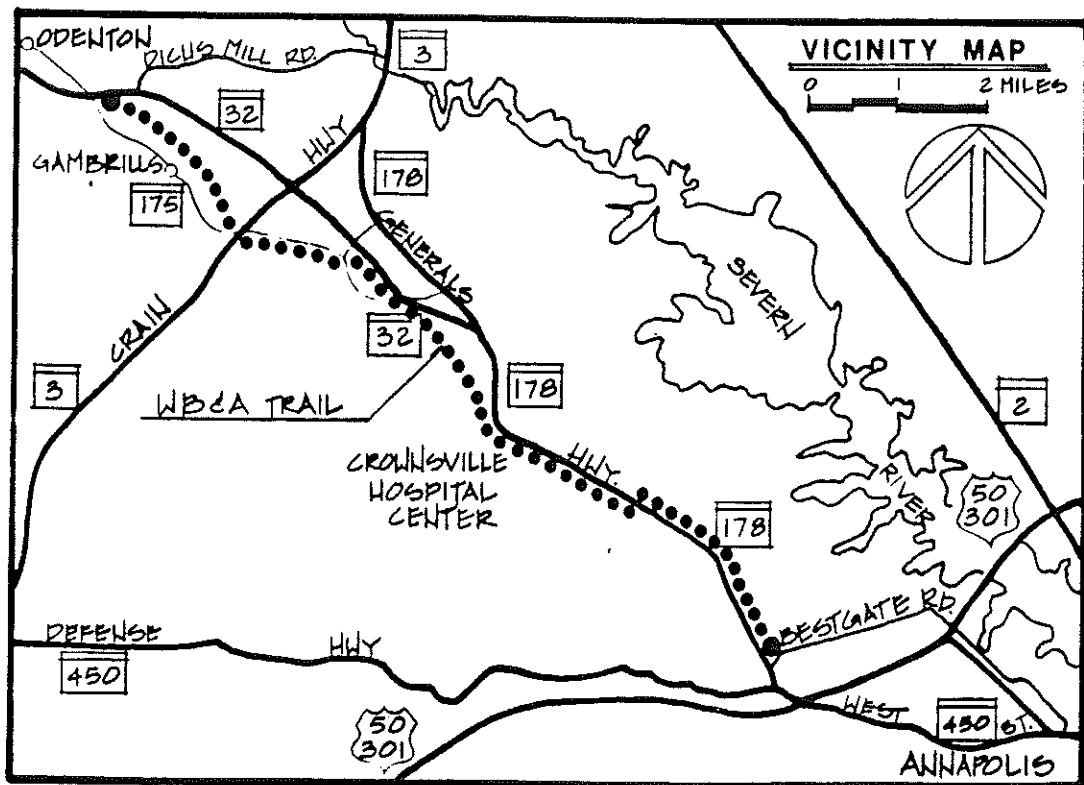

From the beginning of the 20th century until 1935, the Washington, Baltimore & Annapolis Electric Railway was a successful interurban system that linked those three cities, and provided service to the many towns and farms along its route. Seventy-three of the 83 miles making up the extensive network were in Anne Arundel County. In addition to carrying as many as five million passengers annually and spurring development in the area, the WB&A also marked a place in America's history.

The WB&A Electric Railroad was made up of three segments: the mainline from Washington to Baltimore; the south shore route from Annapolis to a junction midway on the mainline; and the north shore route from Baltimore to Annapolis. Each of these lines developed independently of the others. The mainline, built as an electric railway in 1908, paralleled the B&O's Washington Baltimore mainline. The south and north shore routes began as steam lines and were later adapted to electric, the same year the WB&A mainline was completed. The consolidation of the three segments making up the WB&A was directed by George T. Bishop, a business tycoon from Cleveland.

The WB&A south shore route, first chartered the Annapolis & Elkridge Railroad in 1838, was one of the earliest railroads in America. In 1840 a rail line had been completed from New York to Washington with a ferry at the Susquehanna River. Anticipating completion, Annapolis saw the opportunity to connect with the system. In 1837, the A&E Railroad Company began construction on a line linking Annapolis to the B&O's Washington-Baltimore line. Originally, the company planned a terminal at Elkridge; however, the A&E eventually chose a new site eight miles to the south called Annapolis Junction. This site was chosen because it was midway between Baltimore and Washington and offered a favorable topography for a route to Annapolis. The A&E opened for service Christmas Day 1840 and continued until 1887 as the only rail line to Annapolis. The first locomotives on the 20-mile line were woodburners. The A&E's rural route ran through the communities of Odenton, Millersville, Waterbury, Crownsville, Belvoir, Iglehart, Bestgate and Parole to the Annapolis terminal at West Street and Calvert Street.

During the Civil War, the A&E was used as a sea-rail supply route to Washington. In the first year of the war when Yankee troops were attacked in the streets of Baltimore, Union General Butler decided to reach Washington by going around Baltimore. His plan was to take his Massachusetts Regiment of 800 men by barge from the Susquehanna River to Annapolis and continue by A&E Rail to

the B&O Junction and then on to Washington. Upon reaching Annapolis, Governor Hicks and Mayor Magruder protested the army's landing and denied Butler's requests for supplies. They also told the General the A&E track and locomotive had been dismantled. Still determined, Butler marched on to Annapolis Junction. Though the locomotive had been dismantled, the Yankee soldiers were able to reassemble the Massachusetts-built engine. Then the Union troops pushed on, repairing the torn-up track and patrolling the rail line. In one week, the Federal Government controlled a sea-rail route to Washington from the North.

In the decades following the Civil War, rail operations expanded in Anne Arundel County. The old A&E route from Baltimore to Annapolis was roundabout and because of a transfer with the B&O, the trip took two hours. Interest in a more direct line from Baltimore to Annapolis created a second steamline in 1880 - the Annapolis & Baltimore Railroad. After construction of a wood tressle spanning the wide Severn River, the A&B began operations in 1887. The trip from Baltimore's Camden Station to Bladen Street Station in Annapolis took one hour. The line (later called the North Shore Route) passed through the truck farming communities of Geddings, Winchester, Arnold, Round Bay, Boone, Robinson, Marley, Cromwell, Ferndale, Shipley, Linthicum, Pumphrey, and Clifford. Following reorganization in 1894, the A&B was renamed the B&A Short Line Railroad.

After years of marginal existence and competition from the A&B Railroad, the A&E was prompted to reorganize. With the vision of a single rail system connecting Annapolis to Washington and Baltimore, the A&E was renamed the A.W.&B. Railroad in 1886. Beginning in 1902, an electrified line between Washington and Baltimore was completed in 1908. In that same year, the AW&B was purchased by George Bishop, the south shore route was electrified, and the company was renamed the WB&A. Bishop, a successful promoter, was credited with the completion of a similar electric interurban system between Dallas and Fort Worth.

Powered by a 6,600 volt AC overhead catenary system, the WB&A's T-shaped route now connected the three cities by a well-maintained, fast and efficient electric railway. Advertised as one of the wonders of the day, no cost was overlooked in producing a modern railroad of the highest quality. Not coincidentally, the rival A&B Short Line also completed its electrification of the north shore route in the year 1908.



The potential for growth and development in Anne Arundel County at the turn of the 20th century introduced other opportunists to the area. A businessman, Richard Repress, had a grand scheme for building a new city between Baltimore and Washington just north of Annapolis Junction. It was to be a city composed of separate ethnic communities, each governing itself. Although the plan was viewed with skepticism by the local residents, it was supported by George Bishop. The WB&A promoted Repress City offering free transportation to prospective buyers. By 1909, 500 families had purchased land; however, the plan failed to materialize.

In 1917 came WWI and the WB&A was about to make history. Bishop, a shrewd businessman, wasted no time capitalizing on the potential of the floundering Repress City. He bought up the land, some 9,000 acres, and proposed the Federal Government use it for an army camp. After approval by the Campsite Board, the railroad leased the entire tract, called Camp Meade, to the Federal Government and agreed to provide transportation. This was a heyday for the WB&A. The railroad carried 4,000 commuting workmen, materials for 1,200 buildings and accommodated 25,000 soldiers a weekend at 80 cents per roundtrip. In 1917, the railroad earned \$1.5 million and doubled its earnings to \$3 million in 1918. However, the Camp Meade boom was short lived. Following armistice in 1918, the busy wartime activities ceased.

The railroad used the profits from the war years to make improvements. New stations opened in Baltimore at Howard and Lombard Streets and in Washington at 12th and New York. In 1921, the rivalry between the WB&A and the B&A Short Line finally ended and the two lines merged as the WB&A. A connecting track was built in Annapolis. The WB&A had now completed its entire system and would continue just into the next decade. During the 1920s, as many as 70 trains per day would leave Baltimore for Washington or Annapolis.

However, these were the twilight years of the WB&A. In spite of the high quality service, revenues began to dwindle. Maintenance costs and competition from trucks, buses and automobiles brought a gradual decline until the depression forced the company into bankruptcy.

In June 1935, the WB&A was sold at public auction. With the exception of a few short segments, the main line and south shore line were sold for scrap. The north shore line was sold and reorganized as the B&A Railroad. Operations for passenger service continued until 1950, leaving only a freight service that would eventually end in 1968.

Today vestiges of at least seven WB&A stations remain, all on the north shore route: Linthicum, Severna Park, Round Bay, Pasadena, Severn Side, and Jones Station. However, the most significant relics of the WB&A remain for the most part intact: the road beds. These extensive earthworks traversing the County in monumental straight lines remind one of a bygone era, the Railroad Empire.

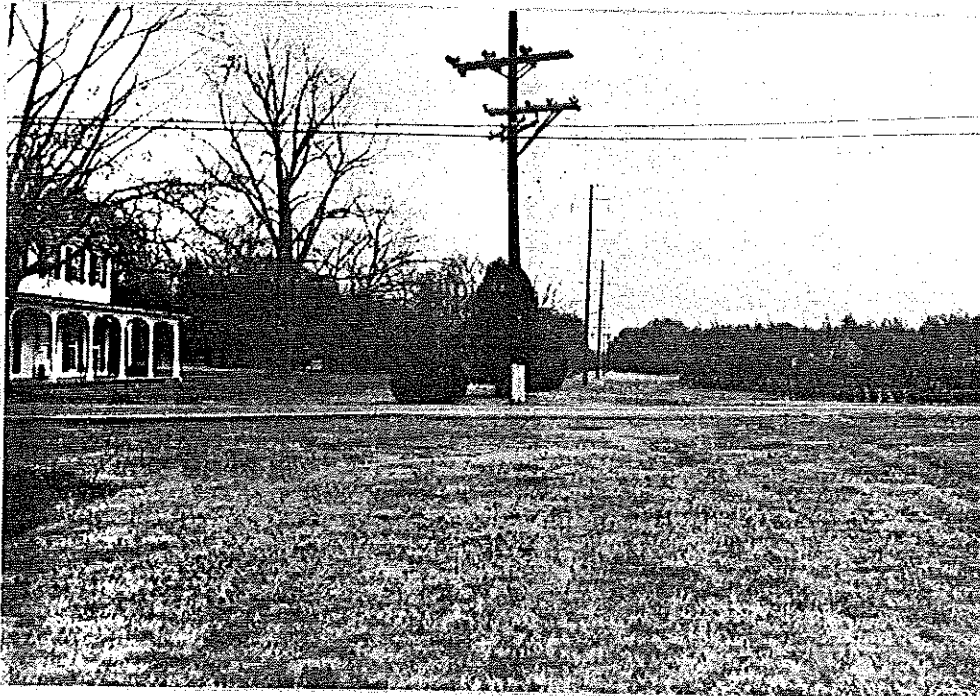

W.B.&A. Trail crossing Cecil Avenue, looking east

Along the WB&A Trail are also other significant historic sites that impacted the early development of this region. Noted on the Master Plan, these include the Generals Highway, five sites listed on the National Register of Historic Places (Belvoir, Iglehart, St. Paul's Church, Rising Sun Inn, Child's Residence) and several other noteworthy landmarks.

NOTE: The historic photographs in this publication are reprinted from Maryland A Pictorial History by Jacques Kelly with permission from the publisher, The Dunning Company, 5659 Virginia Beach Boulevard, Norfolk, VA 23502.

## EXISTING CONDITIONS

Preparing a Master Plan for the WB&A Trail started with gathering data on the existing conditions along the WB&A Trail bed. The bed passes through several environments. Therefore, an inventory of existing conditions was assembled. All of the data was reviewed two ways. First, data was collected to study the future trail construction and insure safe movements for hikers, bikers and drivers. Second, data was collected to study the recreational opportunities for the trail user. In addition, land use examinations located potential generators for the trail such as employment centers, schools, commercial/public centers and parks.

The following list of conditions was inventoried.

- A. Right of Way, Property Ownership
- B. Topography
- C. Vegetation Observed
- D. Utilities
- E. Road Crossings
- F. Drainage
- G. Soils

A companion report, "Study of Storm Drain System along WB&A Trail" was additionally prepared.

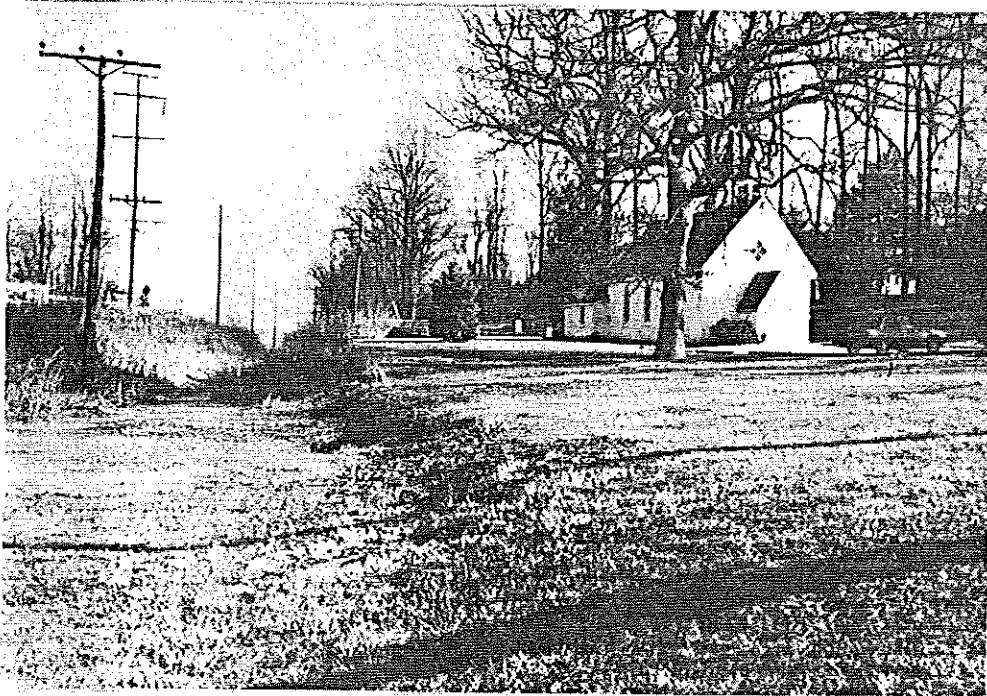

Intersection of Crownsville Rd. & MD Rte 178.

---

## EXISTING CONDITIONS

---

### A. Right of Way, Property Ownership

Most of the WB&A trail from Bestgate Road and Route 178 to Dicus Mill Road and Route 175 is on the old WB&A right-of-way property, and is currently owned by the State Highway Administration. Prints of these record plats and deed data can be obtained from Barry Shear or Ed Chambers, Chief of Records and Research, State Highway Administration, Room 605, 707 N. Calvert Street, Baltimore, MD 21202, (301) 333-1661. These linen metes and bounds plans can also be found at the Anne Arundel County Records Office in Annapolis.

Portions of this SHA right-of-way do not appear on state tax maps because the WB&A property plats were drawn up in 1930 while tax maps were first prepared in 1952 for the sole purpose of tax assessments. The WB&A property was transferred from private to state ownership before 1952.

### B. Topography

Though topography varies along the eight-mile length of the WBA trail, the landforms created by the initial grading for the railroad bed provides continuity. The railroad bed has been graded to the requirements of the historic railroad, any slope is not to exceed 3%. Therefore, in some areas, it was necessary to cut the track bed into a slope. The former track bed is surrounded by high sides which gives the user a quiet, enclosed feeling. A typical slope would be a 2 to 1 slope.

Immediately following a cut slope, a fill condition usually exists. The track bed sits higher than the surrounding land. These high points have an exulting feeling, especially when the land slopes dramatically down into a stream valley. The areas with interesting topography have been noted on the analysis drawings as potential scenic overlooks. These drawings can be found in the Analysis chapter in this report.

Flat open areas relating to the former agricultural use of much of the surrounding land also occur along the trail. These may not be as dramatic as the cut and fill slopes; however, they are a good contrast to the steep slopes.

C. Vegetation Observed

Many different types of trees, shrubs and ground covers along the WB&A Trail are well-established. This variety will enhance the recreational experience for all users of the WB&A Trail. The plant species are primarily native, reflecting the rich quality of the Anne Arundel environment.

Prior to construction, all trees, shrubs and groundcovers should be fenced off for protection. Wherever possible, all existing plant material should be saved, especially on the cut slopes. The linear strip of paving for the trail can be constructed without excessive disturbance. Please note that the cost to reconstruct the existing vegetation would add significantly to the cost of the trail construction.

The following list of plant materials are prevalent throughout the trail. There may be other vegetation, especially grasses and wildflowers, which have not been observed.

Trees:

American Holly, *Ilex americana*  
Beech, *Fagus grandiflora*  
Black Locust, *Robinia pseudoacacia*  
Maple species, *Acer sp.*  
Oak species, *Quercus sp.*  
Sassafras, *sassafras albidum*  
Tulip Poplar, *Liriodendron tulipifera*

Shrubs and Groundcovers:

Bamboo species  
Bittersweet, *Celastris Scandens*  
Daffodils, *Narcissus*  
Ferns  
May Apples, *Podyphyllum Peltatum*  
Periwinkle, *Vinca Major*  
Joe Pye Weed, *Eupatorium Maculatum*  
Scotch Broom, *Cytisus Scoparius*  
Skunk Cabbage, *Symplocarpus Foetidus*  
Sumac, *Rhus Species*

Please note this is a partial list of the vegetation along the WB&A bed.

---

## EXISTING CONDITIONS

---

### D. Utilities

Baltimore Gas & Electric Company has an easement through this property for overhead electric lines.

The trail only crosses gas lines at road intersections.

### E. Road Crossings

There are 23 road crossings along the WB&A trail. The majority of these crossings are over rural roads with low traffic counts (at this writing). Route 3, southbound and northbound, and Route 175 (at the intersection of Route 3) represent major crossings. Other major road crossings occur at the intersection of Old Generals Highway and Route 178, and at the intersection of Route 178 and Route 32. These major roads have existing signals which will aid the hiker/biker. Besides road crossings, there is one short section the WB&A trail where users will have to use the shoulder of the roadway. A barrier device will be required to separate trail users from motorists. This occurs on Waterbury Road between Bacon Ridge and Genco Lane.

Road crossings are perhaps more critical for the cyclist who desires to maintain momentum. The trail should not lead a cyclist or hiker into a dangerous situation. Adequate signs or pavement crossing marks must be installed. Each crossing on the WB&A trail will represent a different problem that must be addressed in the final design and construction of the trail. Crosswalks on County-owned roads should be installed as per County Standards.

<u>Crossings</u>	<u>Road Type</u>	<u>Comments</u>
Burns Crossing Rd.	Rural	Limited Site Distances Angled Crossing
Gambrills Rd.	Rural	
Holladay St.	Residential	No Curbs

EXISTING CONDITIONS

<u>Crossings</u>	<u>Road Type</u>	<u>Comments</u>
Rt 3 Southbound	Arterial	Signal/Major Crossing
Rt 3 Northbound	Arterial	Signal/Major Crossing
Rt 175 (Millersville Rd)	Major	Signal/Difficult Crossing
Hansel Drive	Residential	
Cecil Ave	Rural	No Curbs
Nichols Road	Residential	No Curbs/Dirt Road
Arundel Station	Residential	No Curbs/Dirt Road
Waterbury Rd	Rural	Limited Site Distances, Difficult Crossing and Road Curves
Waterbury/ Bacon Ridge	Rural	Share Roadway with Vehicles
Waterbury/Genco Lane	Residential	No Curbs, Share Roadway with Vehicles
Route 32	Major	Signal - Begin I-197
Fairfield Loop (close proximity to South Shore Elementary School)	Rural	
Crownsville Road at 178	Major	Signal, Difficult Crossing 3179 Daily Trips
Honeysuckle Lane	Rural	No Curbs
Route 178	Major	Difficult, Signals
The Old Generals Hwy South end	Rural	
Dunton Rd	Residential	No Curb
Carriage Hill Pkwy	Residential	
Epping Forest Rd	Rural	2780 Daily Trips

---

## EXISTING CONDITIONS

---

As previously mentioned, the majority of road crossings along the WB&A trail are over low-use, rural/residential roads. Future development will affect the number of trips generated in the county and inevitably affect the safety, maintenance, and installation of road crossings.

### F. Drainage

The majority of the trail lies on the major drainage divide between the Severn River and the South River.

The hydrology and storm drain structures along the trail have been field investigated and followed up with preliminary computations, the results of which are included in a separate report. Of the total 23 culverts under the trail, approximately 10-11 will need replacing. Several of these culverts are stone box culverts built in the 1830s. When a stone box culvert is replaced, efforts should be made to salvage the large 2'x6' slabs of rock for benches or other amenities along the trail.

### G. Soils

Most of the soils along the trail are moderately drained except in low areas, particularly where the old train bed lies below the adjacent grades. The most significant area of this type is located near the northwest end of the site where the soil is classified as hydric. The hydric soil and standing water indicates a potential wetland and suggests locating the trail at a higher elevation adjacent to this depressed railroad bed. Two other areas adjacent to the trail have hydric soils indicating potential wetlands. One is near Bestgate Road and the other near Waterbury Road; however, the trail is on the raised railroad bed above these soils.



The WB&A train bed is a linear corridor that passes through various micro-climates, land uses and transportation routes. Future users will have rich and varied experiences along the trail.

All of the existing conditions (manmade and natural) along the WB&A train bed were considered and evaluated in terms of the proposed use, a hiker/biker trail. Some portions of the future trail will be used as community trails, especially those portions of the WB&A train bed that pass by elementary schools. This analysis looks at the WB&A train bed in its entire length ( $\pm 10$  miles) as a recreational asset for Anne Arundel County.

The entire length of the WB&A train bed was walked and photographed. In most cases, the bed is easy to identify. Only one portion of the train bed has been totally changed, the area required to build Interstate 97 and the off/on ramp to/from Rt. 32.

In order to summarize the opportunity and problem areas for a hiker/biker trail along the WB&A corridor, nine drawings were made. These drawings were originally on the Anne Arundel County maps at 1"=200'. These drawings have been reduced. They begin at the southeast terminus (Bestgate Rd.) and continue along the WB&A train bed to the northwest terminus at Rt. 32.



Dirt lane adjacent to WB&A bed,  
approaching Holladay Park Road

## Analysis Key

Consistent symbols are used in each drawing. The key for these symbols can be found on drawing one or in the following key.



Beginning/end of trail - need for parking, signs & entrance treatment

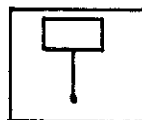

Potential for interpretive sign

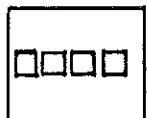

Trail on WB&A train bed

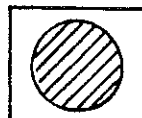

Potential site for rest stop/picnic area



New trail bed



Streams & swales



WB&A train bed



Slopes



Views into scenic wooded areas

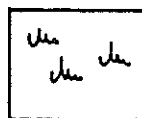

Wet areas

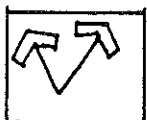

Views into scenic open areas

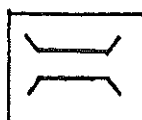

Site that needs to be spanned



Wooded area



Junk yards or dumping sites

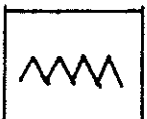

Buffer



Site of former historic train station

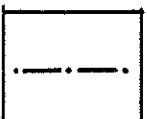

Guard rail



Road crossing - need for signs, traffic control and/or crosswalks

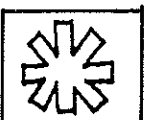

Potential access point, parking potential

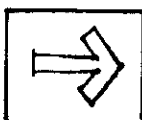

Secondary trail for access

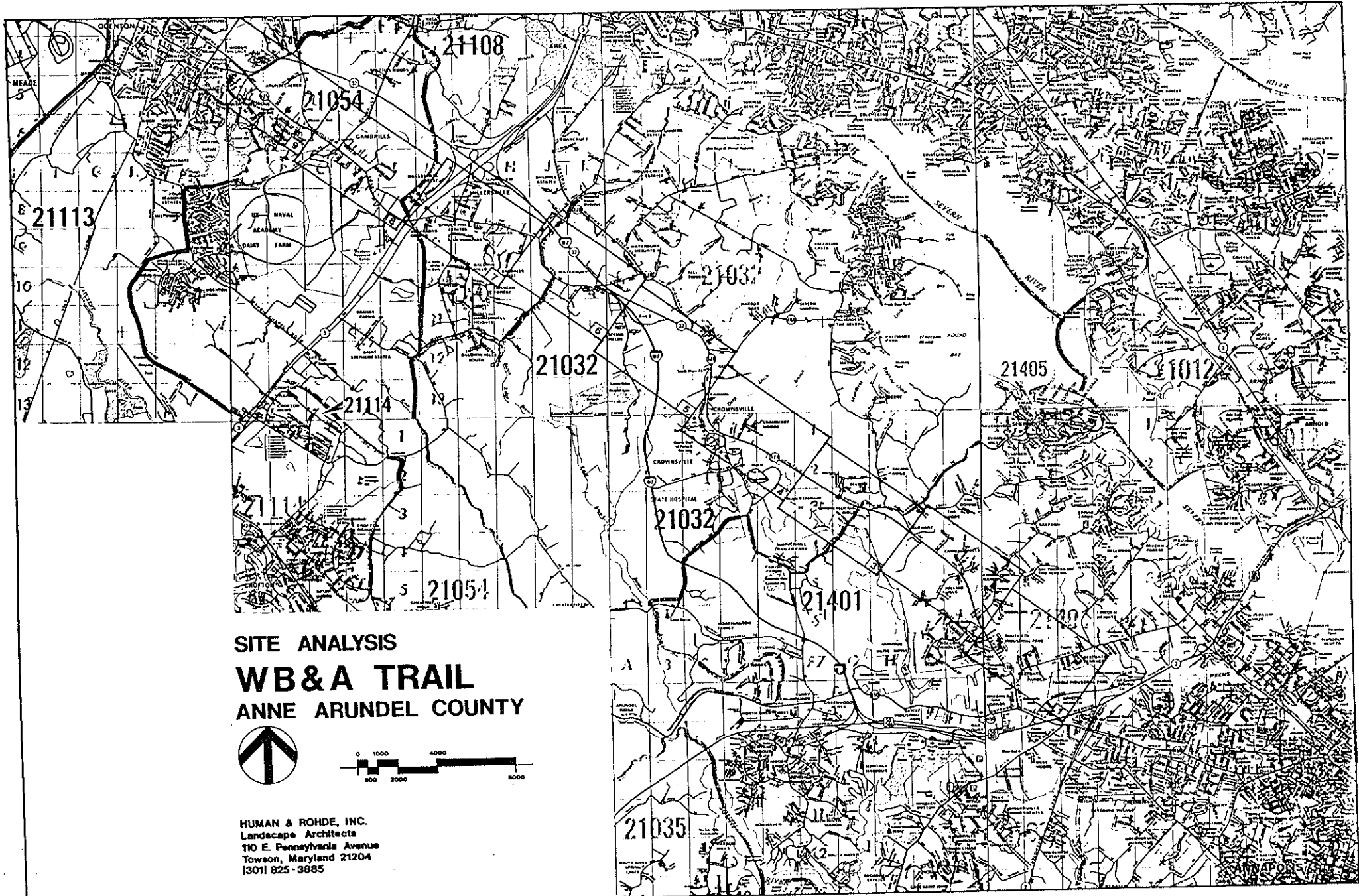







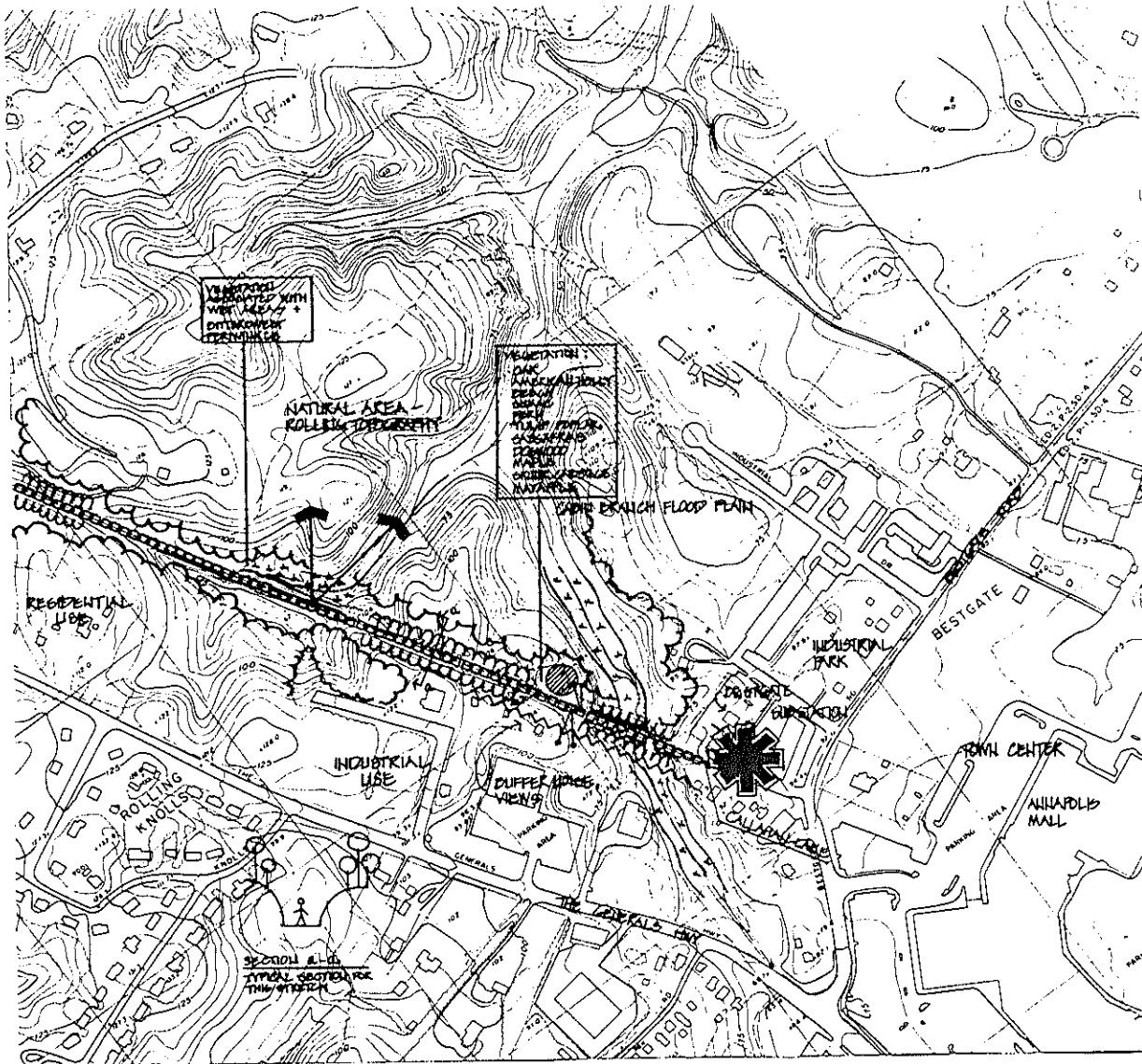













**SITE ANALYSIS**  
**WB&A TRAIL**  
**ANNE ARUNDEL COUNTY**



HUMAN & ROHDE, INC.  
Landscape Architects  
110 E. Pennsylvania Avenue  
Towson, Maryland 21204  
(301) 825-3885



**KEY**

-  BEGINNING/END OF TRAIL - SIGNALS A HUBED FOR PARKING, SIGNALS A ENTRANCE TREATMENT
-  TRAIL ON W.D 4A TRAIL BED
-  TRAIL NOT ON W.D 4A TRAIL BED
-  W.D 4A TRAIL BED
-  VIEWS INTO SCENIC WOODED AREAS
-  VIEWS INTO SCENIC OPEN AREAS
-  WOODED AREAS
-  BUFFER
-  GUARD RAIL
-  POTENTIAL ACCESS POINT, PARKING POTENTIAL
-  POTENTIAL AREA FOR AN INTERPRETIVE SIGN
-  POTENTIAL SITE FOR A REST STOP/PICNIC AREA
-  STREAMS & SWALES
-  SLOPES
-  WET AREAS
-  SITE THAT NEEDS TO BE OBTAINED
-  JUNK YARDS OR DUMPING SITES
-  SITE OF FORMER HISTORIC TRAIN STATION
-  ROAD CROSSING - SIGNALS A NEED FOR SIGNALS, TRAFFIC CONTROL, CROSS MARKS
-  SECONDARY TRAIL FOR ACCESS

*Handwritten signature/initials*

**HUMAN & RORDE, INC.**  
 Landscape Architects  
 110 E. Pennsylvania Avenue  
 Towson, Maryland 21204  
 (301) 825-3885

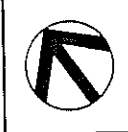

ANNE ARUNDEL COUNTY DEPARTMENT OF PUBLIC WORKS					
REVISED DATE	APPROVED DATE	DATE	DRAWN BY	SCALE	SITE ANALYSIS
			J.R.	1" = 200'	
CHECKED BY	DATE	DATE	PROJECT NO.	SHEET NO.	
		11/11/00	P-5120	1 OF 1	
APPROVED	DATE	DATE	PROPOSAL NO.	MAP NO.	
			2105		
CHIEF OF RIGHT OF WAY DIVISION	DESIGN ENGINEER				

WB & A TRAIL

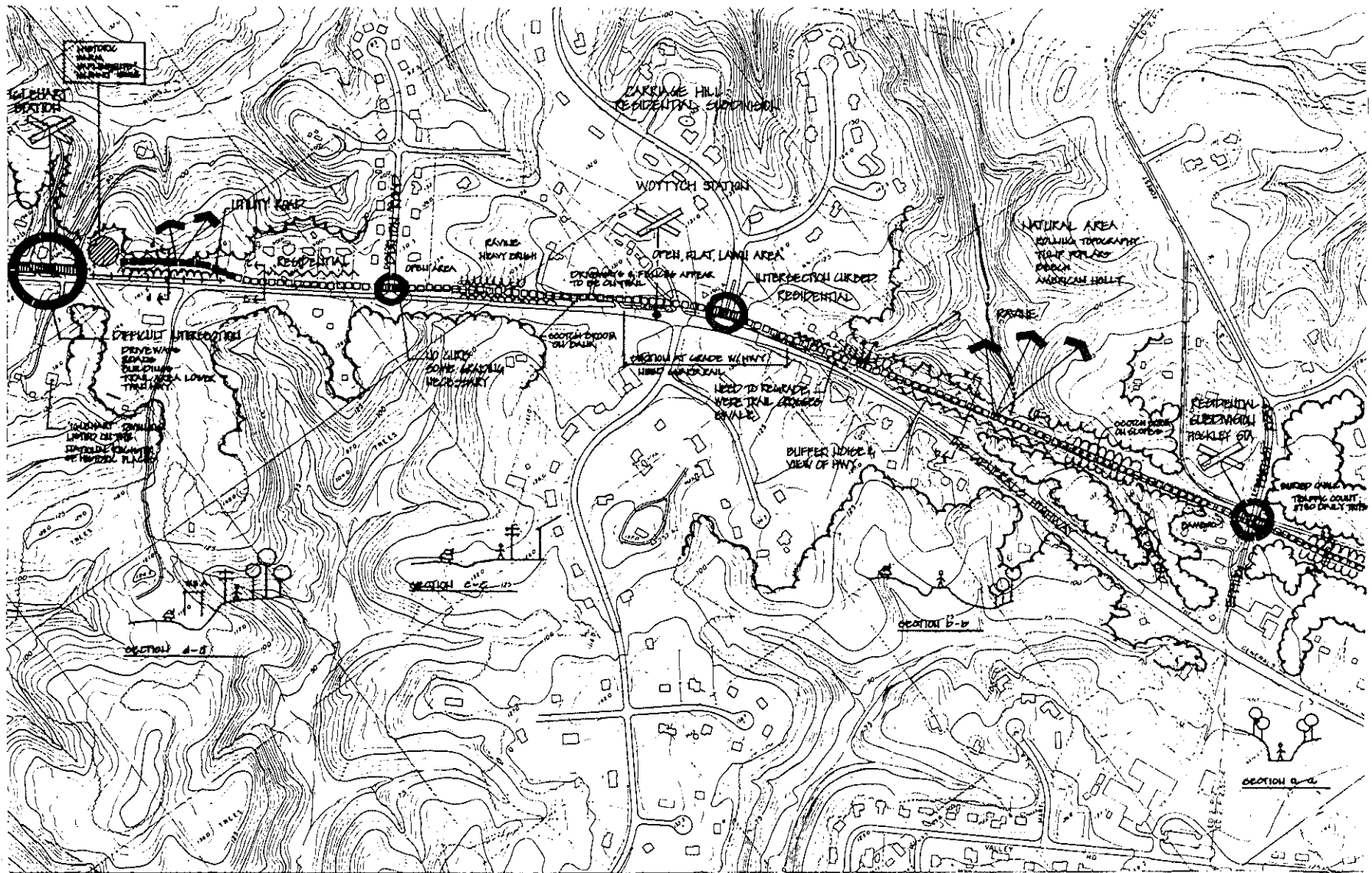

STATE OF MARYLAND  
*Handwritten signature/initials*

HUMAN & ROHDE, INC.  
 Landscape Architects  
 110 E. Pennsylvania Avenue  
 Towson, Maryland 21204  
 (301) 825-3885



ANNE ARUNDEL COUNTY  
 DEPARTMENT OF PUBLIC WORKS

REVISED DATE	APPROVED BY	DATE	DRAWN BY	SCALE	TITLE
	CHIEF ENGINEER		DATE	1" = 200'	WBCA TRAIL
	BUREAU SUPERVISOR		CHECKED BY		
	POINT OF WAY ASSUMED		DATE		
	APPROVED		DESIGN ENGINEER		
	CHIEF OF BUREAU OF WAY DIVISION				

June 1/2/97

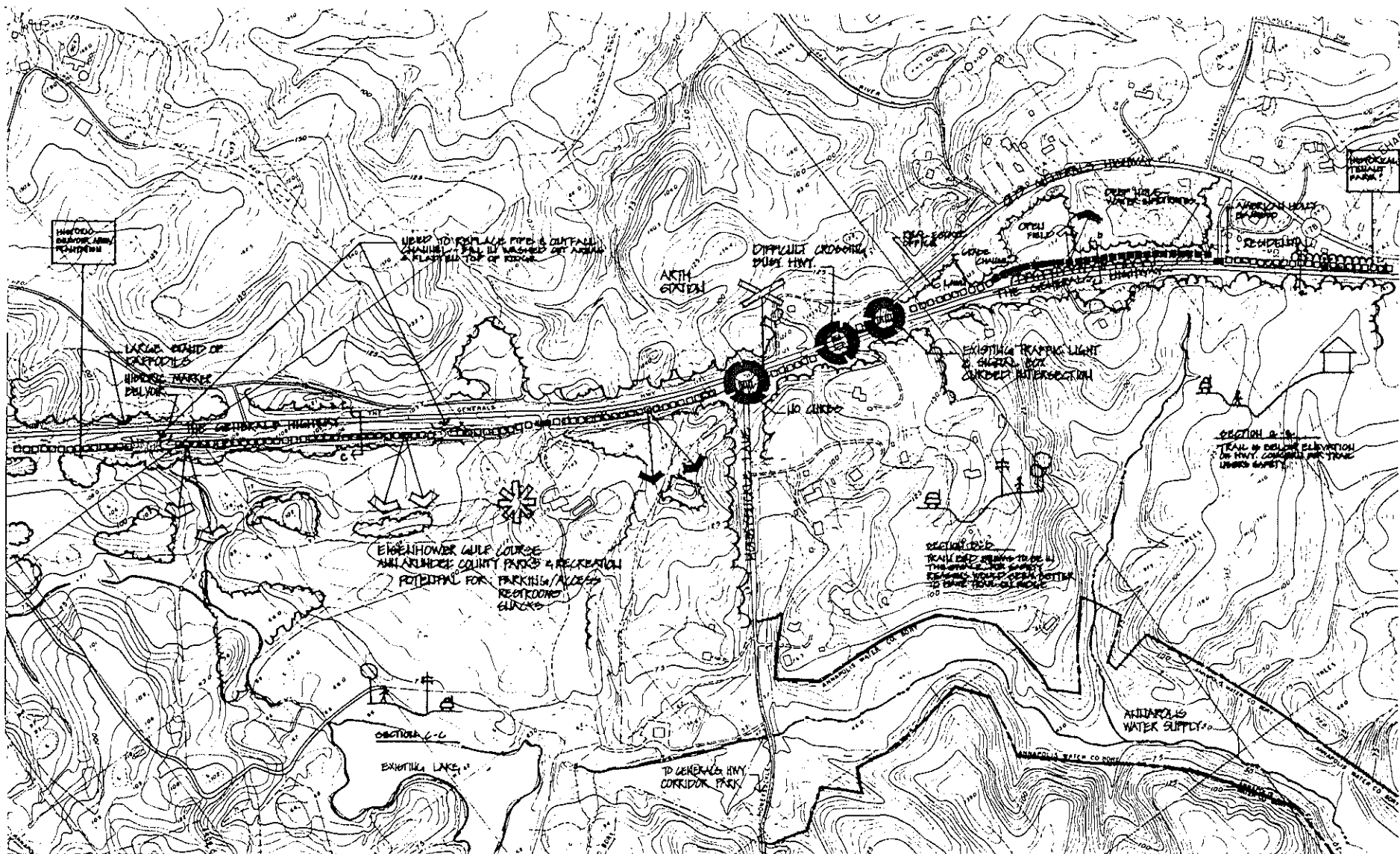

*check*

HUMAN & ROHDE, INC.  
Landscape Architects  
110 E. Pennsylvania Avenue  
Towson, Maryland 21204  
13011 825-3885



NO. USED		DATE		APPROVED	DATE	DRAWN BY	CHECKED BY	SCALE	SITE ANALYSIS
						J. H.	J. R.	1" = 200'	
				CHIEF ENGINEER				SHEET NO 5 OF 9	
				AUXILIARY ENGINEERS				PROJECT NO P2120	
				RIGHT OF WAY ACQUIRED	DATE	DATE ACQ'D		PROPOSAL NO 2103	WBCA TRAIL
				CHIEF OF RIGHT OF WAY DIVISION		DESIGN ENGINEER		MAP NO	

10/1/01

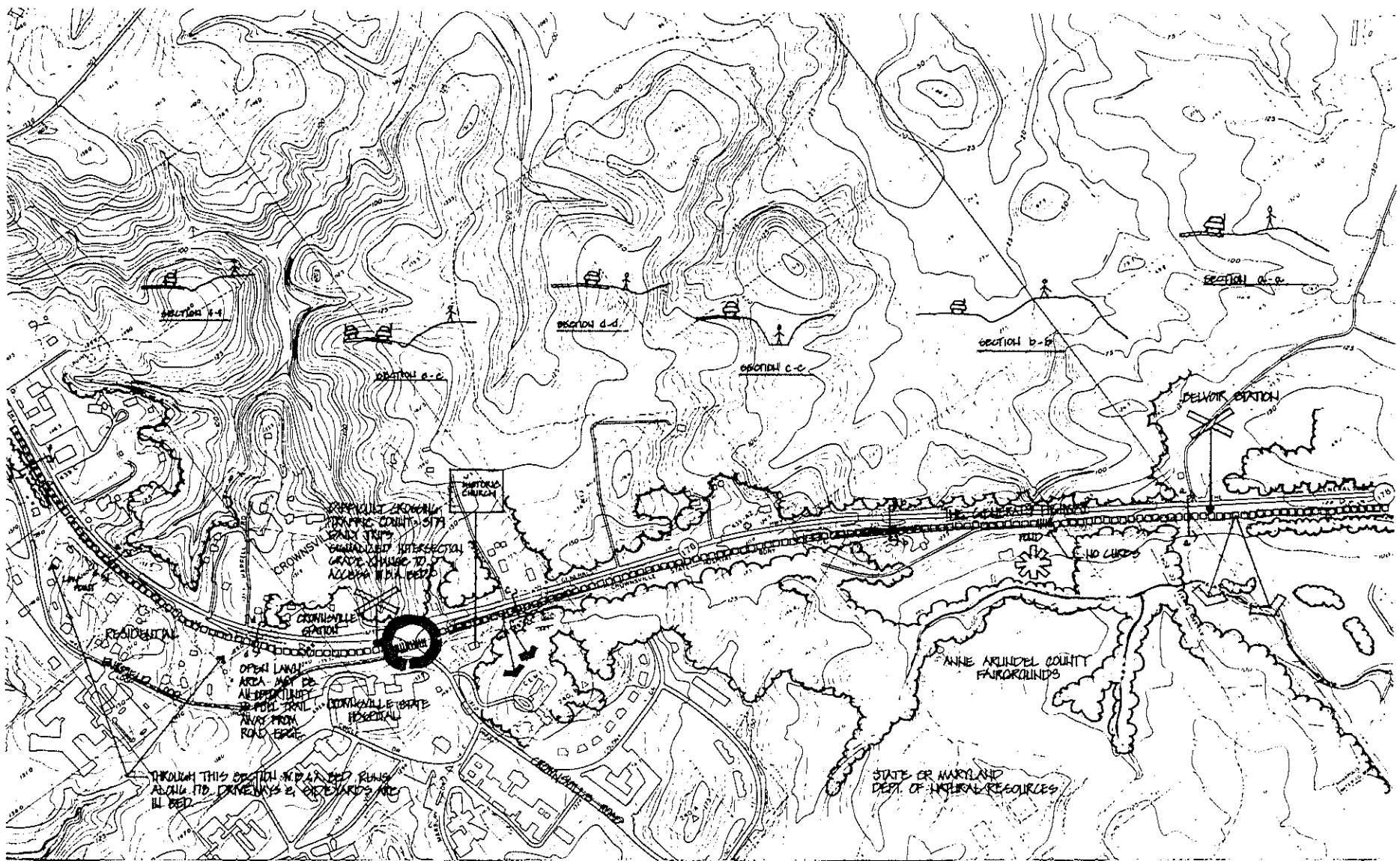

*Checked*

HUMAN & ROHDE, INC.  
Landscape Architects  
110 E. Pennsylvania Avenue  
Towson, Maryland 21204  
301) 825-3885



ANNE ARUNDEL COUNTY DEPARTMENT OF PUBLIC WORKS					
NO. DRAWN	APPROVED	DATE	DRAWN BY	SCALE	SITE ANALYSIS
001			CP	1" = 200'	
CHECKED BY	DATE	DATE	DATE	PROJECT NO.	
				P3707	
CHIEF ENGINEER	DATE	DATE	DATE	PROJ. NO.	
				E195	
CHIEF OF RIGHT OF WAY DIVISION	DATE	DATE	DATE	MAP NO.	

WBCA TRAIL

11/14

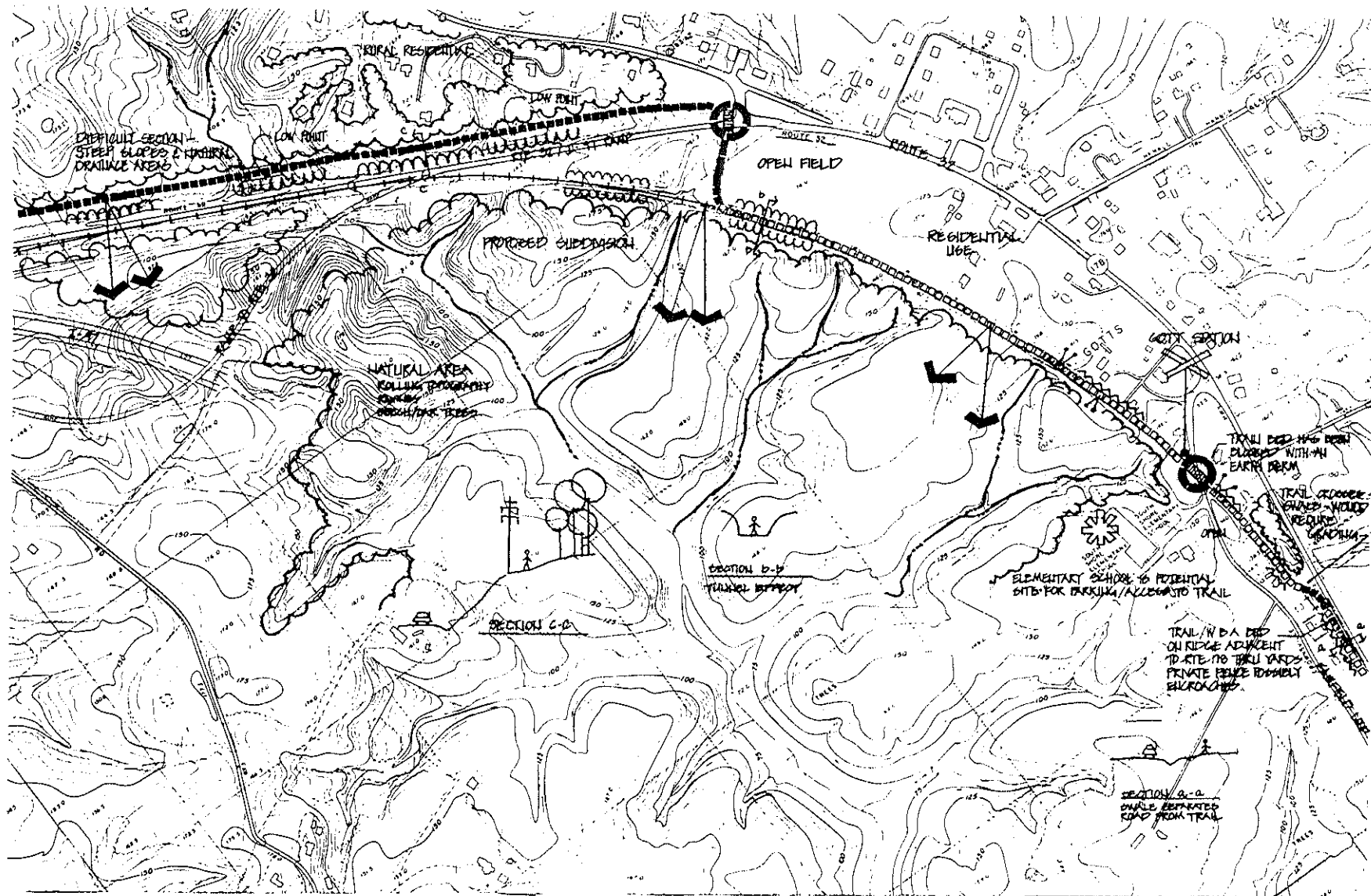

*decker*

HUMAN & RÖHDE, INC.  
Landscape Architects  
110 E. Pennsylvania Avenue  
Towson, Maryland 21204  
(301) 825-3885



ANNE ARUNDEL COUNTY DEPARTMENT OF PUBLIC WORKS					
REVISION	APPROVED	DATE	DRAWN BY	SCALE	SITE ANALYSIS
DATE	BY				
	CHIEF ENGINEER		CHECKED BY	PROJECT NO.	WB & A TRAIL
	BUREAU OF ENGINEERING	DATE	DATE	PROPOSAL NO.	
	CHIEF OF BUREAU OF ROAD DIVISION	DESIGN ENGINEER	DATE	PROPOSAL NO.	

1/16/10



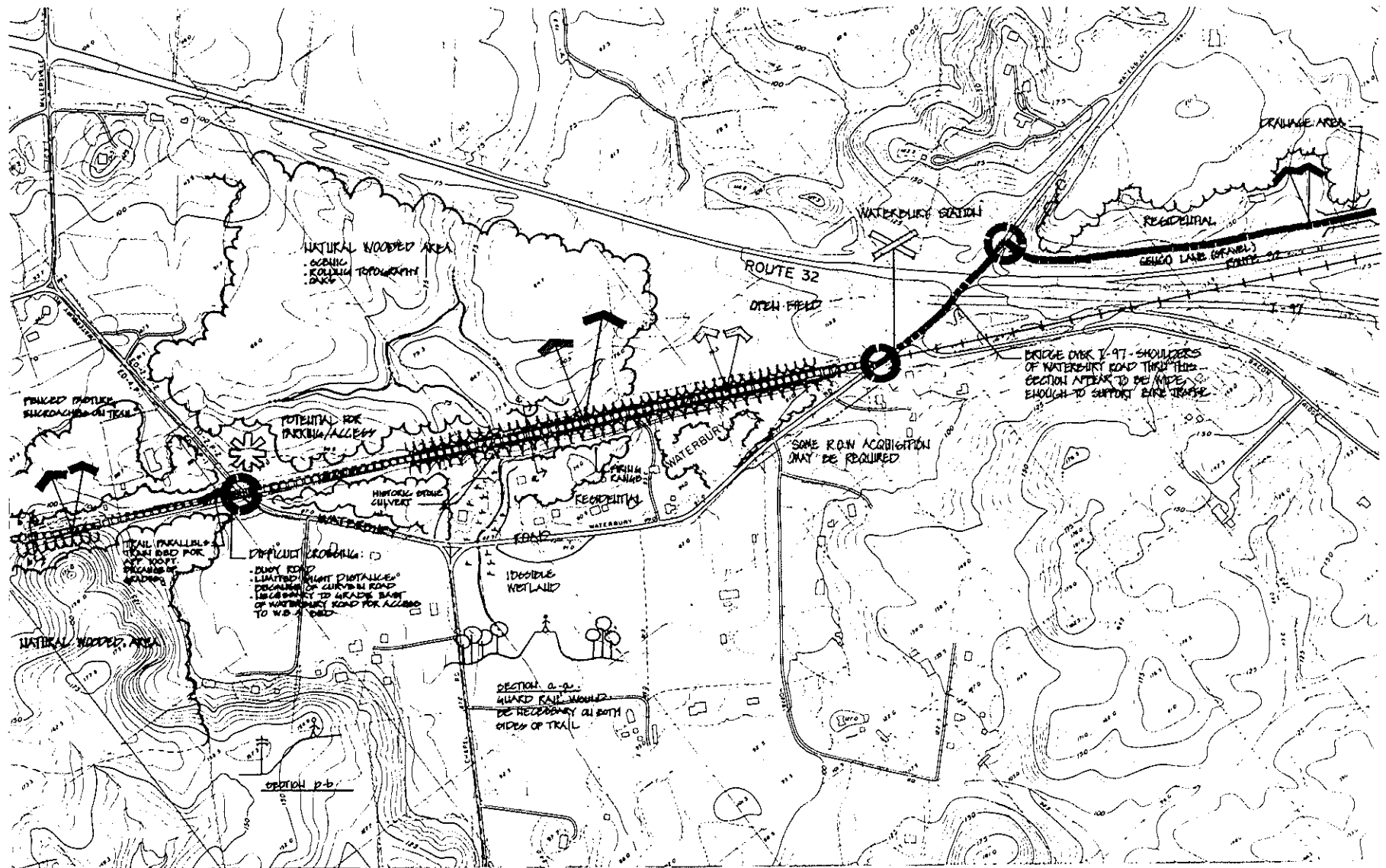

*Leads*

HUMAN & RORDE, INC.  
Landscape Architects  
110 E. Pennsylvania Avenue  
Towson, Maryland 21204  
13011 825 - 3885



ANNE ARUNDEL COUNTY DEPARTMENT OF PUBLIC WORKS						DATE	SITE ANALYSIS	
DESIGNED BY	APPROVED	DATE	DRAWN BY	SCALE				
CHECKED BY	CHEF OF DIVISION	DATE	CHECKED BY	SCALE				
RIGHT OF WAY ACQUIRED	DATE		DATE ACQUIRED	SCALE				
DATE APPROVED	DESIGN ENGINEER		DATE APPROVED	SCALE				
CHIEF OF RIGHT OF WAY DIVISION	DESIGN ENGINEER		CHIEF OF RIGHT OF WAY DIVISION	SCALE				

WB SA TRAIL

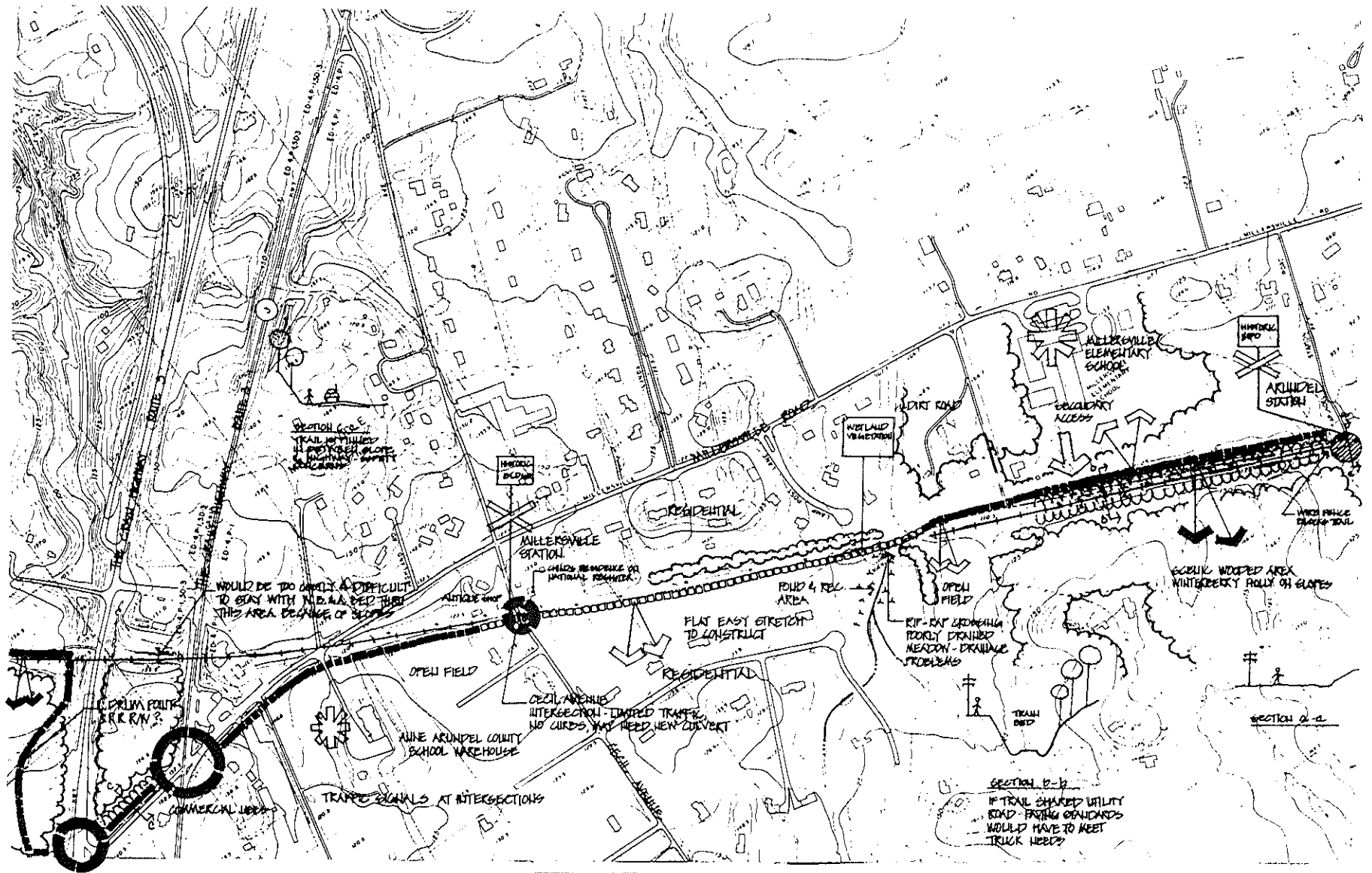

*Handwritten signature:* J. Rohde

HUMAN & ROHDE, INC.  
 Landscape Architects  
 110 E. Pennsylvania Avenue  
 Towson, Maryland 21204  
 13011 825-3885

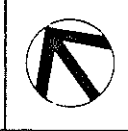

ANNE ARUNDEL COUNTY DEPARTMENT OF PUBLIC WORKS					
APPROVED	DATE	DRAWN BY	SCALE	SHEET NO.	SITE ANALYSIS
CHIEF ENGINEER		W. H. ROHDE	1" = 200'	7 OF 8	WB & A TRAIL
PROJECT ENGINEER					
DATE APPROVED					
PROJECT NO.					
PROPOSAL NO.					
CHIEF OF RIGHT OF WAY DIVISION		DESIGN ENGINEER			

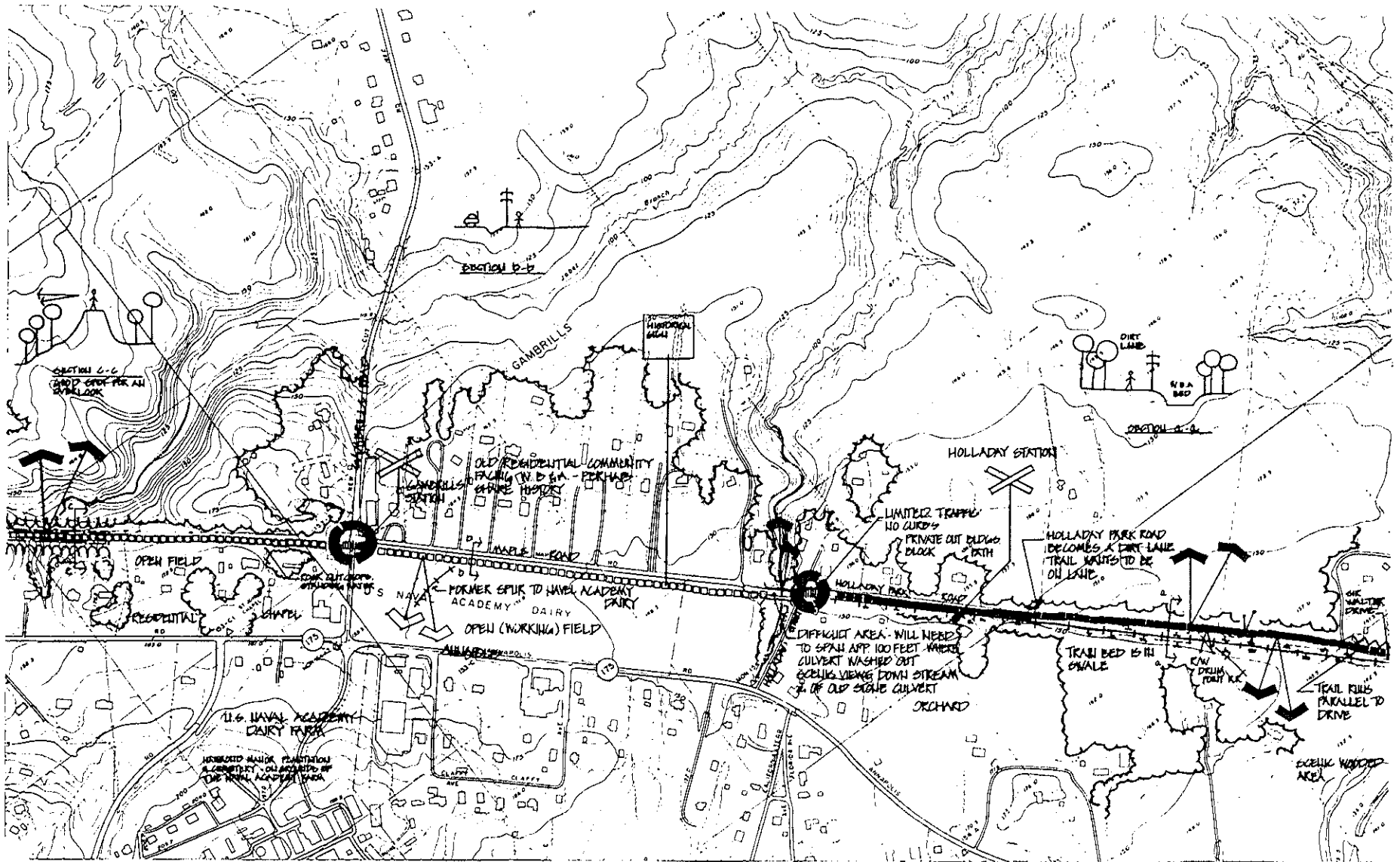

*John*  
 1/20/01  
 11/2/01

HUMAN & ROHDE, INC.  
 Landscape Architects  
 110 E. Pennsylvania Avenue  
 Towson, Maryland 21204  
 13011 825-3885



ANNE ARUNDEL COUNTY  
 DEPARTMENT OF PUBLIC WORKS

REVISION	DATE	BY	APPROVED	DATE	BY	DRAWN BY	SCALE
			CHIEF ENGINEER			5/01	1" = 200'
			SUPERVISOR OF ENGINEERING			5/01	SHEET NO. 8 OF 8
			PROJECT ENGINEER			5/01	PROJECT NO. P5700
			APPROVED			5/01	PROFESSOR NO. 2105
			CHIEF OF RIGHT OF WAY DIVISION			5/01	MAP NO.

SITE ANALYSIS  
 WPC A TRAIL

11/2/01

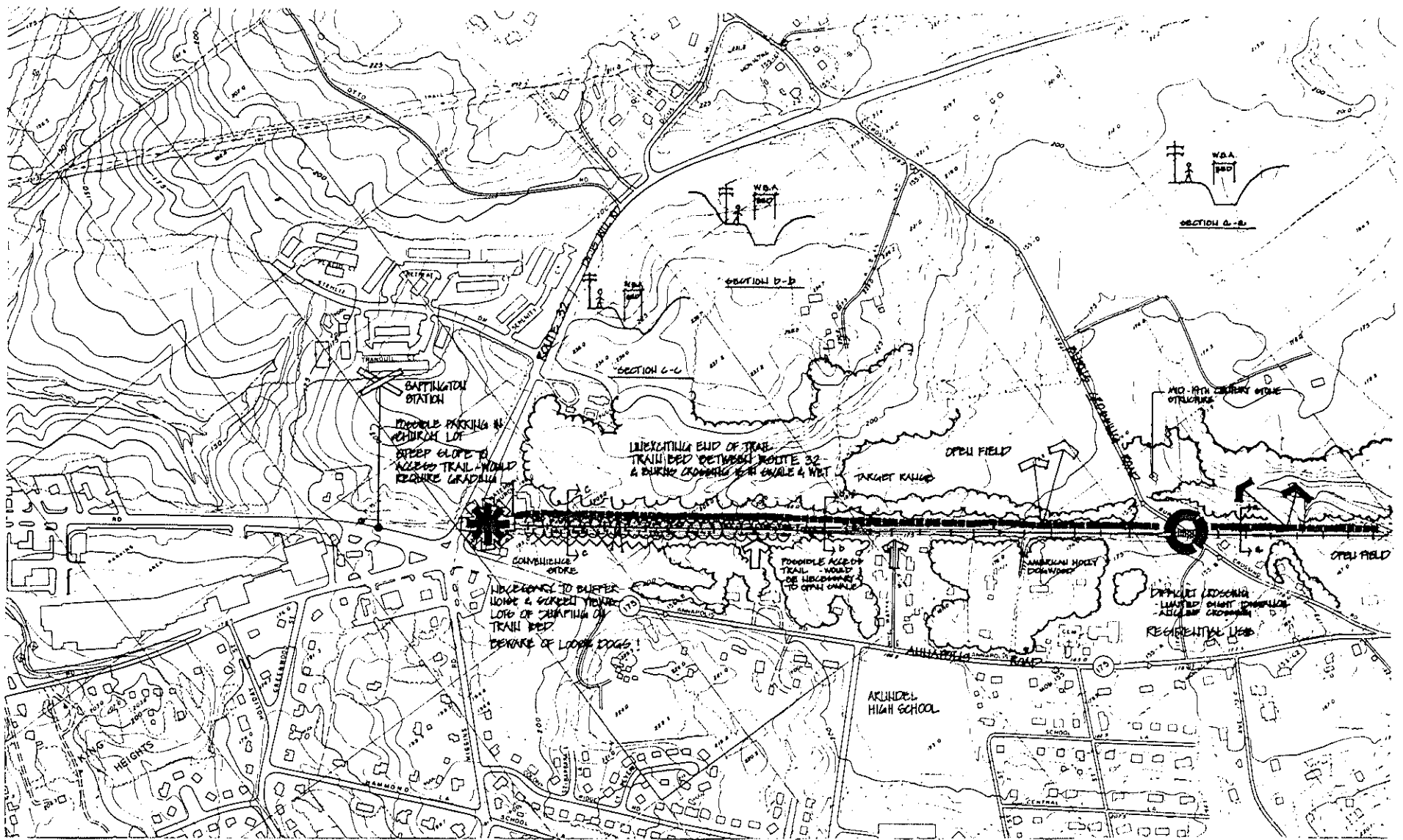

*dec 14*

HUMAN & ROHDE, INC.  
Landscape Architects  
110 E. Pennsylvania Avenue  
Towson, Maryland 21204  
(301) 825-3885



ANNE ARUNDEL COUNTY DEPARTMENT OF PUBLIC WORKS					
DESIGNED BY	APPROVED	DATE	DRAWN BY	SCALE	SITE ANALYST
DATE	DATE	DATE	DATE	DATE	DATE
CHIEF ENGINEER	BUREAU OF CONSTRUCTION	CHIEF OF RIGHT OF WAY DIVISION	DESIGN ENGINEER	PROJECT NO. 89710	PROPOSAL NO. 2195

WB & A TRAIL

Nov 16/14

## PROPOSED TRAIL ALIGNMENT

The proposed trail alignment is illustrated on the following pages. Similar to the Analysis plans, these drawings were originally drawn on the Anne Arundel County Maps, scale: 1" = 200'. They have been reduced for this publication. The proposed trail alignment was determined jointly by the Anne Arundel County Department of Public Works and by the Department of Recreation and Parks. Alternatives to the alignment were presented for review. Special study areas were identified and enlarged for site specific investigation. These study areas helped to identify hazards or areas of special interest.

The following drawings begin at the southeast terminus (Bestgate Road) and continue along the WB&A trail to the northwest terminus at Rt. 32. In contrast to the analysis drawings, the proposed trail alignment offers solutions to problems, i.e., grading, and offers advice for the best use of opportunity areas, i.e., view overlook/rest areas.

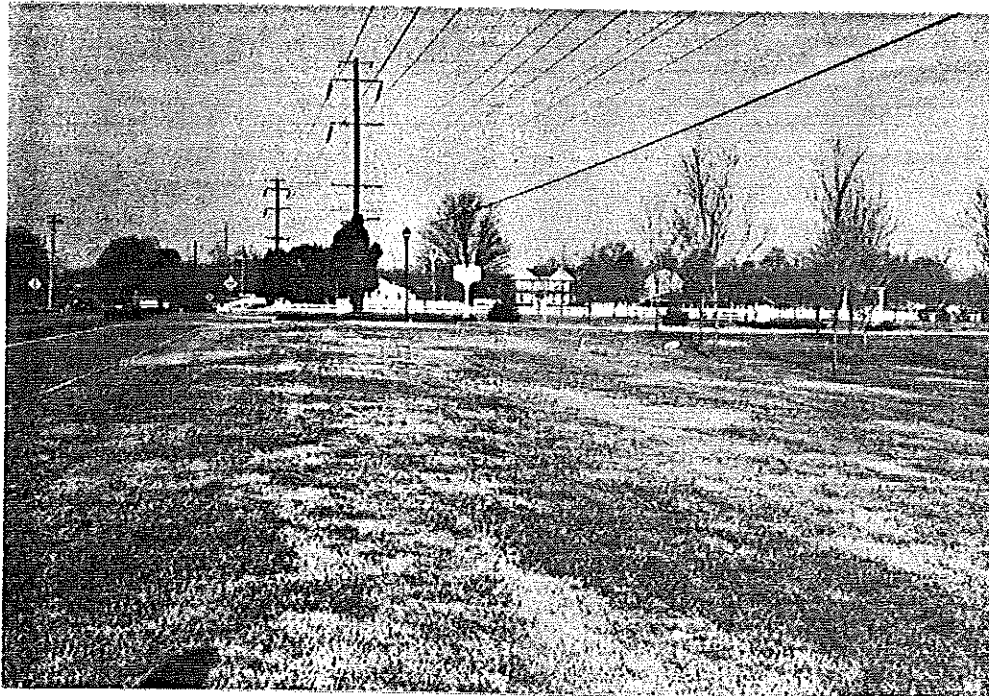

WB&A Trail along Rte 178, adjacent to  
Carriage Hill subdivision

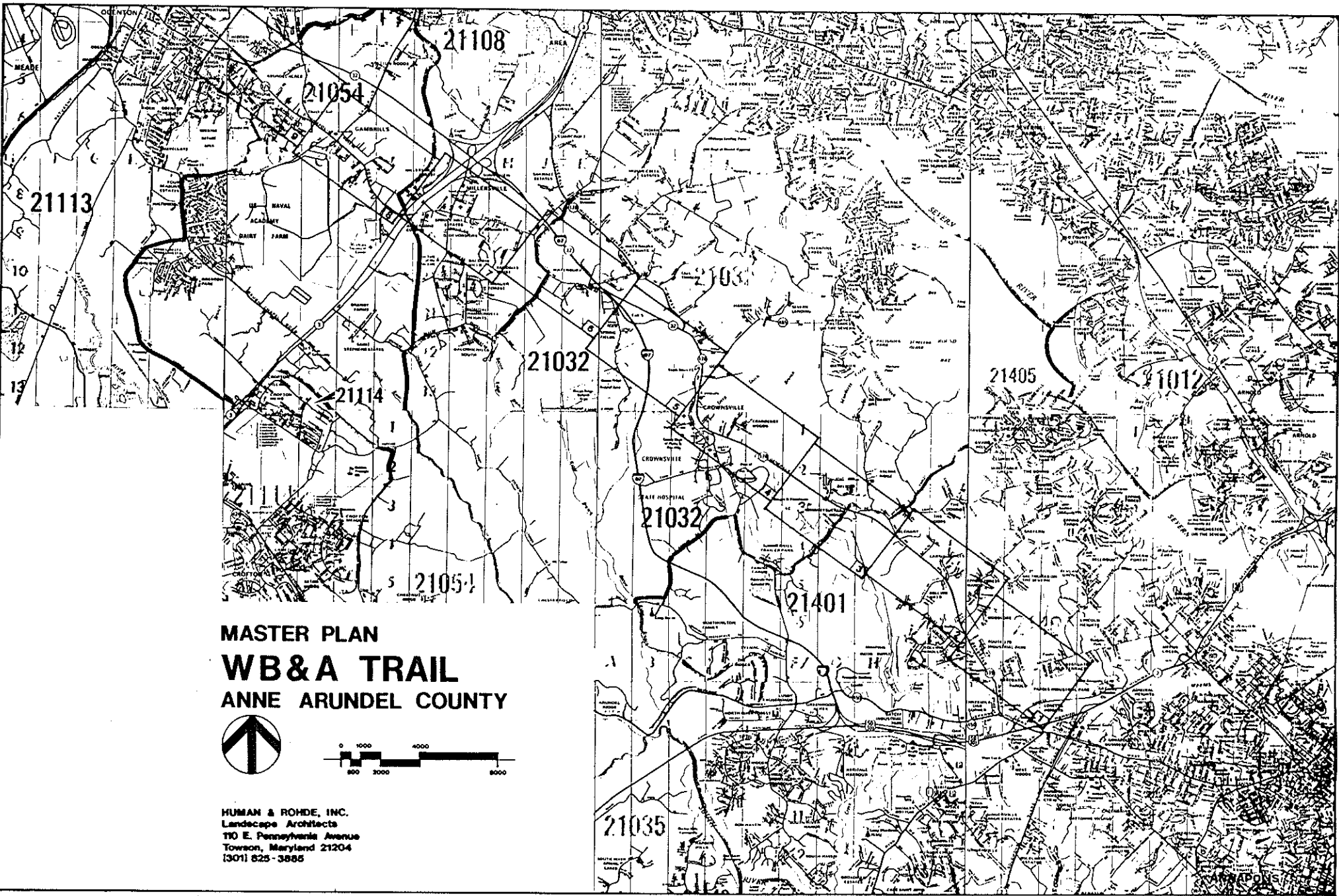

**MASTER PLAN**  
**WB&A TRAIL**  
**ANNE ARUNDEL COUNTY**



**HUMAN & ROHDE, INC.**  
Landscape Architects  
110 E. Pennsylvania Avenue  
Towson, Maryland 21204  
(301) 825-3885

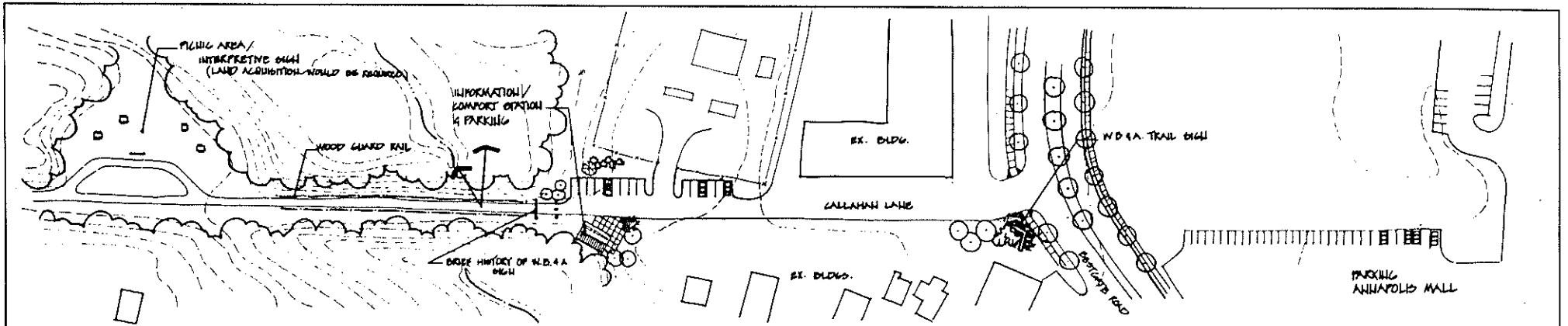

**STUDY AREA 1**  
SCALE: 1" = 50'

THE CURVE IN DESIGNATED ROAD AT CALLAHAN LANE PROVIDES A PEDESTRIAN CROSSING TO THE ANNAPOLIS MALL IN THIS LOCATION. AN ENTRANCE TO THE MALL IS PLANNED FOR INDUSTRIAL DRIVE AND DESIGNATE ROAD. A PEDESTRIAN CROSSING SHOULD OCCUR AT THAT INTERSECTION.

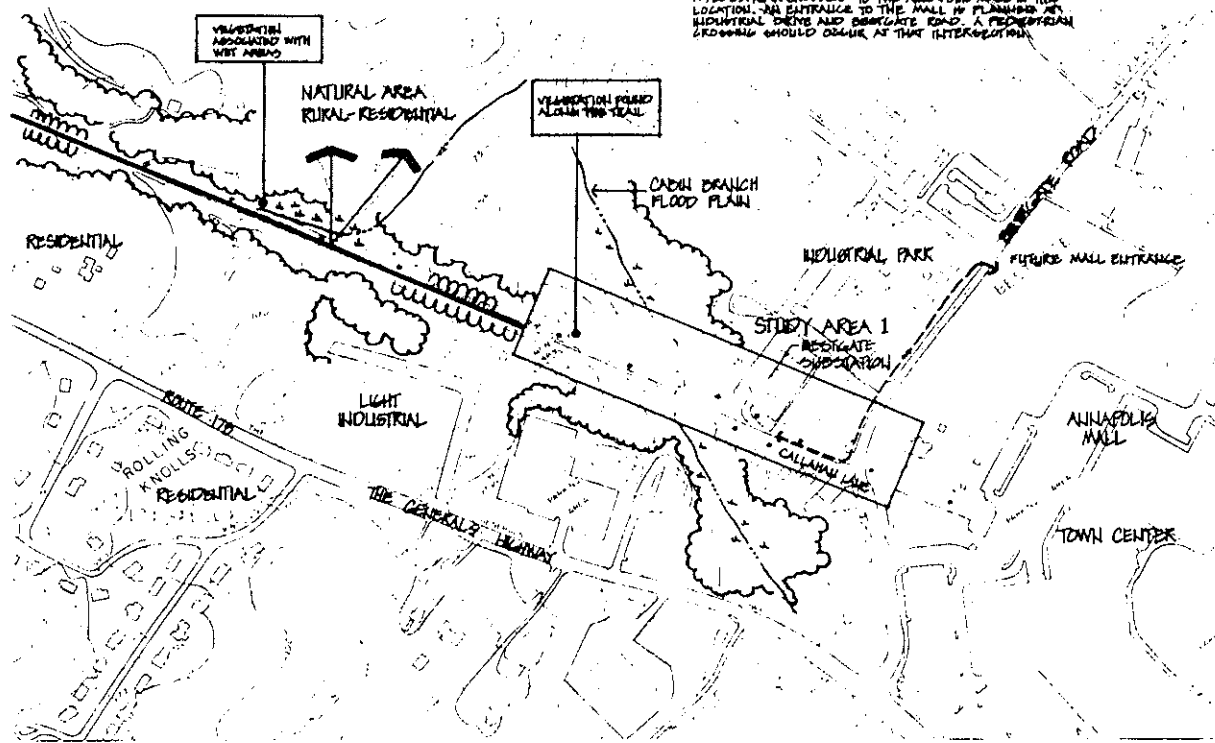

**KEY**

	W.D.G.A. TRAIL		STREAMS / GNALES
	W.D.G.A. TRAIN BED WHERE TRAIL IS ON IT		GROPPES
	SECONDARY TRAIL ACCESS		WET AREAS
	POTENTIAL PARKING AREAS		AREA TO BE SPINNED
	ALTERNATE TRAIL ROUTE		INTERPRETIVE SIGN / HISTORIC MARKER
	WOODED AREA		TRAIN STATION MARKER
	PROPOSED BUFFER PLANTING		GUARD RAIL
	REST STOP		INTERSECTION OF W.D.G.A. TRAIL & ROADWAY - INDICATES A NEED FOR: 1. APPROPRIATE CHANGING FOR VEHICLES & TRAIL USERS. 2. PHYSICAL BARRIERS TO PREVENT UNAUTHORIZED VEHICLES FROM USING TRAIL.
	OVERHEAD UTILITY LINES		
	VIEWS		

*Handwritten signature/initials*

HUMAN & ROHDE, INC.  
Landscape Architects  
110 E. Pennsylvania Avenue  
Towson, Maryland 21204  
(301) 825-3885



ANNE ARUNDEL COUNTY							
DEPARTMENT OF PUBLIC WORKS							
REVISED BY	DATE	APPROVED	DATE	DRAWN BY	SCALE	SHEET NO.	OF #
				J.R.	1" = 100'		
				CHECKED BY			
				J.R.			
				DATE			
				JANUARY 14, 1985			
				APPROVED			
				DIRECTOR DEPT. OF P.W.	CADSW. ENGINEER	PROGRAM NO.	MAP NO.
						305	
							MASTER PLAN
							WB & A TRAIL

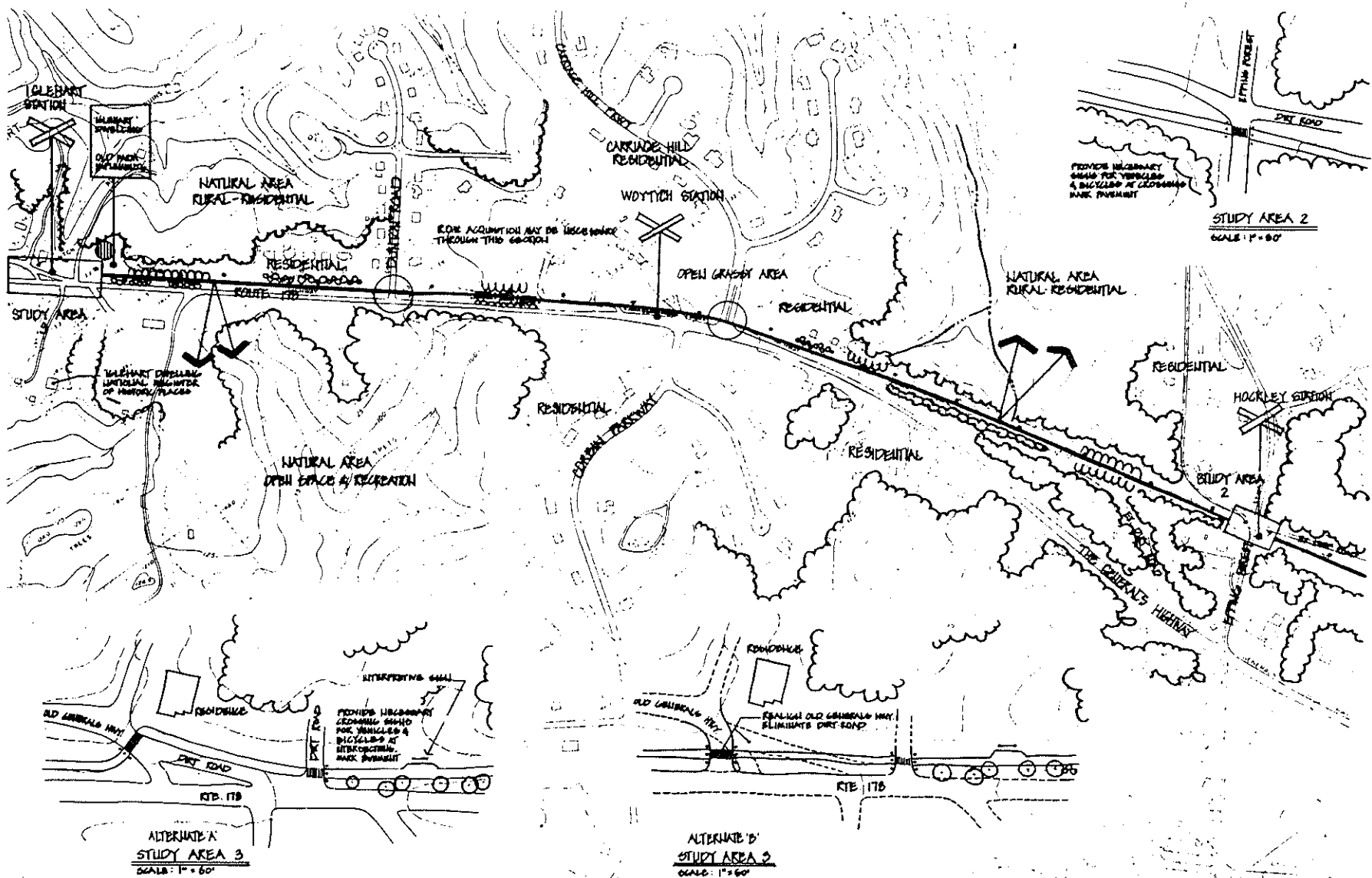

**ALTERNATE A**  
**STUDY AREA 3**  
SCALE: 1" = 60'

**ALTERNATE B**  
**STUDY AREA 2**  
SCALE: 1" = 60'



**HUMAN & RORDE, INC.**  
Landscape Architects  
110 E. Pennsylvania Avenue  
Towson, Maryland 21204  
(301) 825-3885



ANNE ARUNDEL COUNTY			
DEPARTMENT OF PUBLIC WORKS			
REVISED	DATE	BY	SCALE
			1" = 200'
			MASTER PLAN
APPROVED	DATE	DESIGNED BY	PROJECT NO.
			P-1120
APPROVED	DATE	DESIGNED BY	PROJECT NO.
			P-1120
APPROVED	DATE	DESIGNED BY	PROJECT NO.
			P-1120

WETA TRAIL



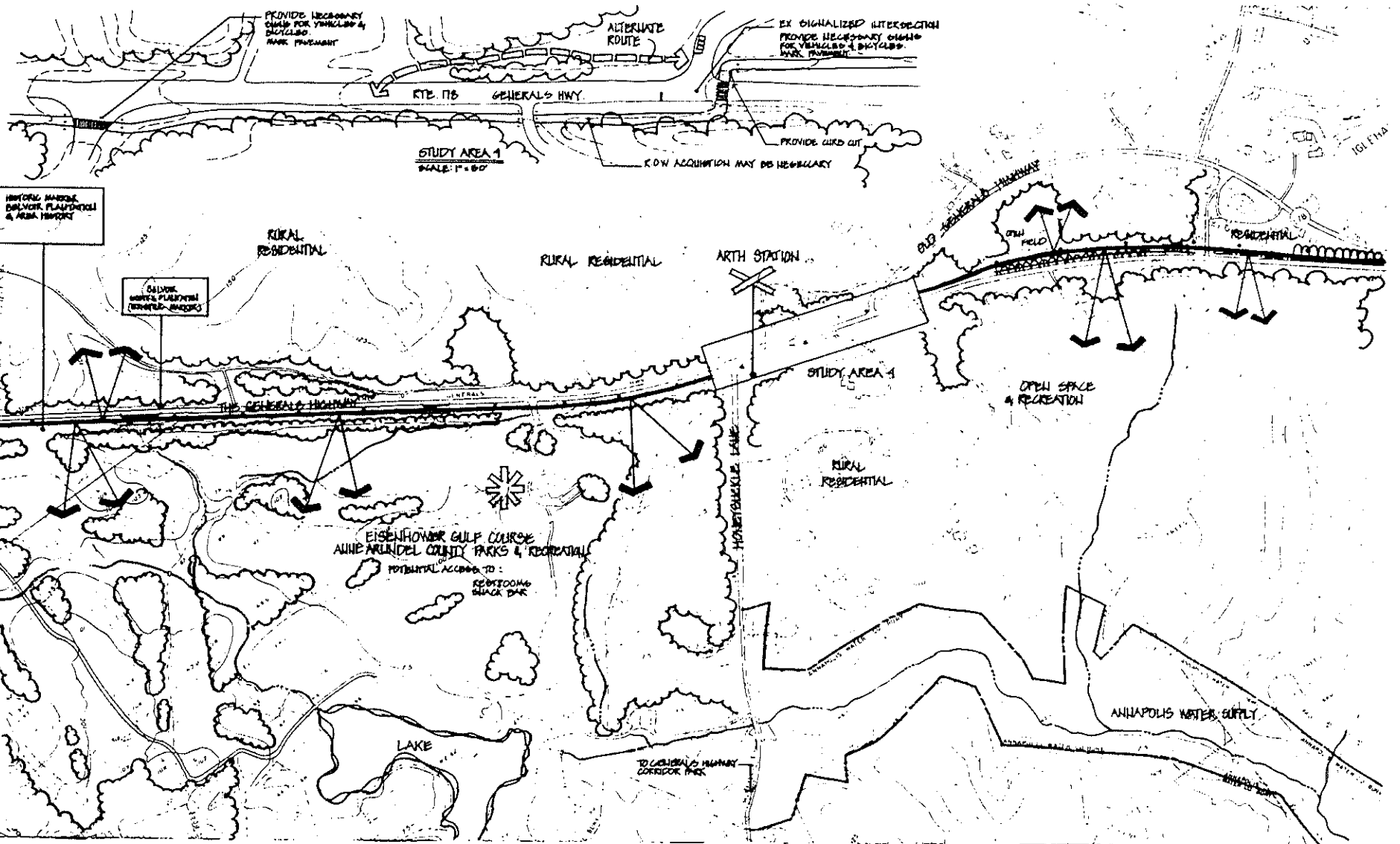

HISTORIC MARKER  
DELIVER PLANTING  
& AREA HISTORY

CALLOW  
WATER PLANTING  
(POND/SHRUBS)

RURAL  
RESIDENTIAL

RURAL RESIDENTIAL

ARTH STATION

STUDY AREA 1

RURAL  
RESIDENTIAL

OPEN SPACE  
& RECREATION

EISENHOWER GOLF COURSE  
ANNE ARUNDEL COUNTY PARKS & RECREATION

POTENTIAL ACCESS TO:  
RECREATION  
BLACK BAR

LAKE

ANnapolis WATER SUPPLY

TO GENERAL'S HWY  
CORRIDOR PARK

STUDY AREA 1  
SCALE: 1" = 80'



HUMAN & ROHDE, INC.  
Landscape Architects  
110 E. Pennsylvania Avenue  
Towson, Maryland 21204  
13011 825-3885



ANNE ARUNDEL COUNTY  
DEPARTMENT OF PUBLIC WORKS

REVISED	DATE	BY	APPROVED	DATE	BY	DESIGNED	DATE	SCALE	SHEET NO	TOTAL SHEETS
						J.R.	JANUARY 14, 1990	1" = 200'	5	4
						J.R.				
						J.R.				
						J.R.				
						J.R.				
						J.R.				
						J.R.				
						J.R.				

MASTER PLAN  
WBCA TRAIL

PROPOSAL NO 2122

MAP NO

DESIGN ENGINEER

WELCOME DEPT. OF REC. & PLEAS.

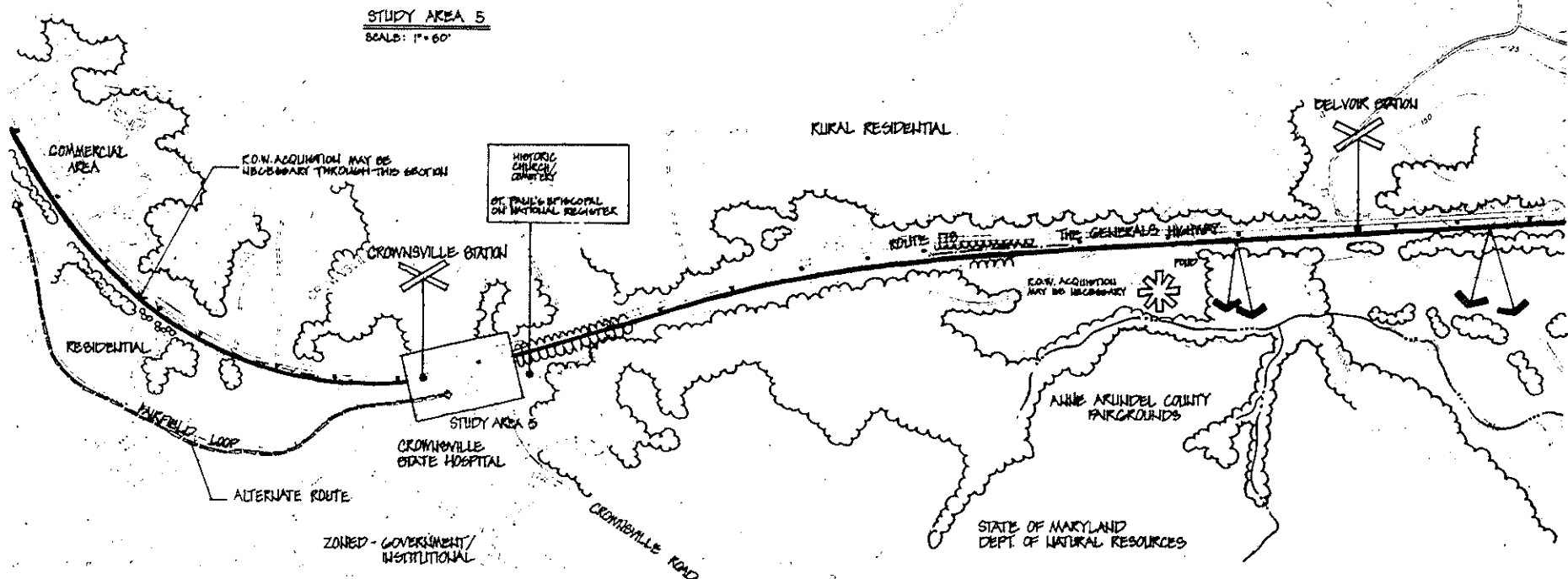
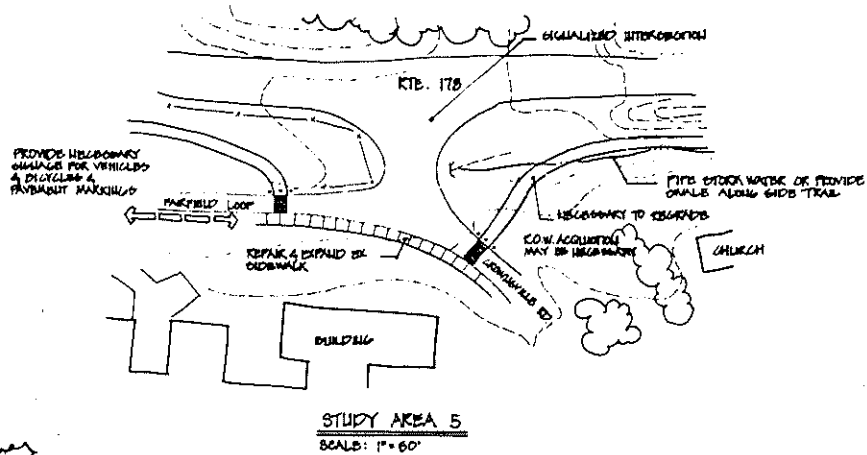

HUMAN & RHODE, INC.  
Landscape Architects  
110 E. Pennsylvania Avenue  
Towson, Maryland 21204  
1301/ 825-3885



ANNE ARUNDEL COUNTY DEPARTMENT OF PUBLIC WORKS						
REVISED DATE	BY	APPROVED	DATE	DRAWN BY	SCALE	SHEET NO. 4 OF 4
				J.P.	1/20	MASTER PLAN
				J.P.		PROJECT NO. 1122
						PROPOSAL NO. 273
						MAP NO.

WB & A TRAIL

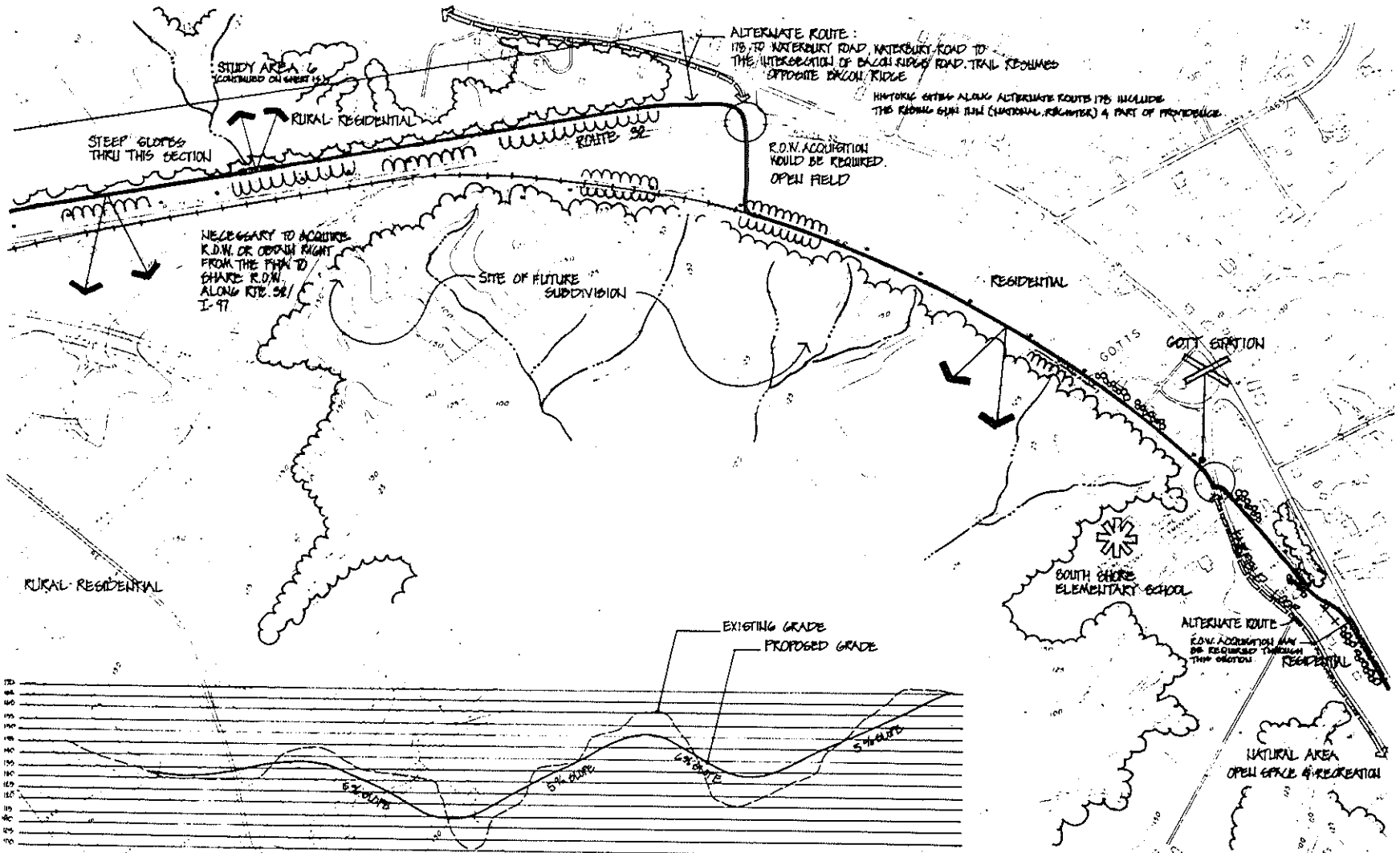

STUDY AREA 6  
 HORIZONTAL SCALE: 1" = 200'  
 VERTICAL SCALE: 1" = 20'



HUMAN & ROHDE, INC.  
 Landscape Architects  
 110 E. Pennsylvania Avenue  
 Towson, Maryland 21204  
 (301) 825-3885



ANNE ARUNDEL COUNTY					
DEPARTMENT OF PUBLIC WORKS					
REVISION	DATE	BY	DATE	SCALE	PROJECT NO.
				1" = 200'	WB & A TRAIL
					PROPOSAL NO. 2158
					DESIGN ENGINEER

WB & A TRAIL

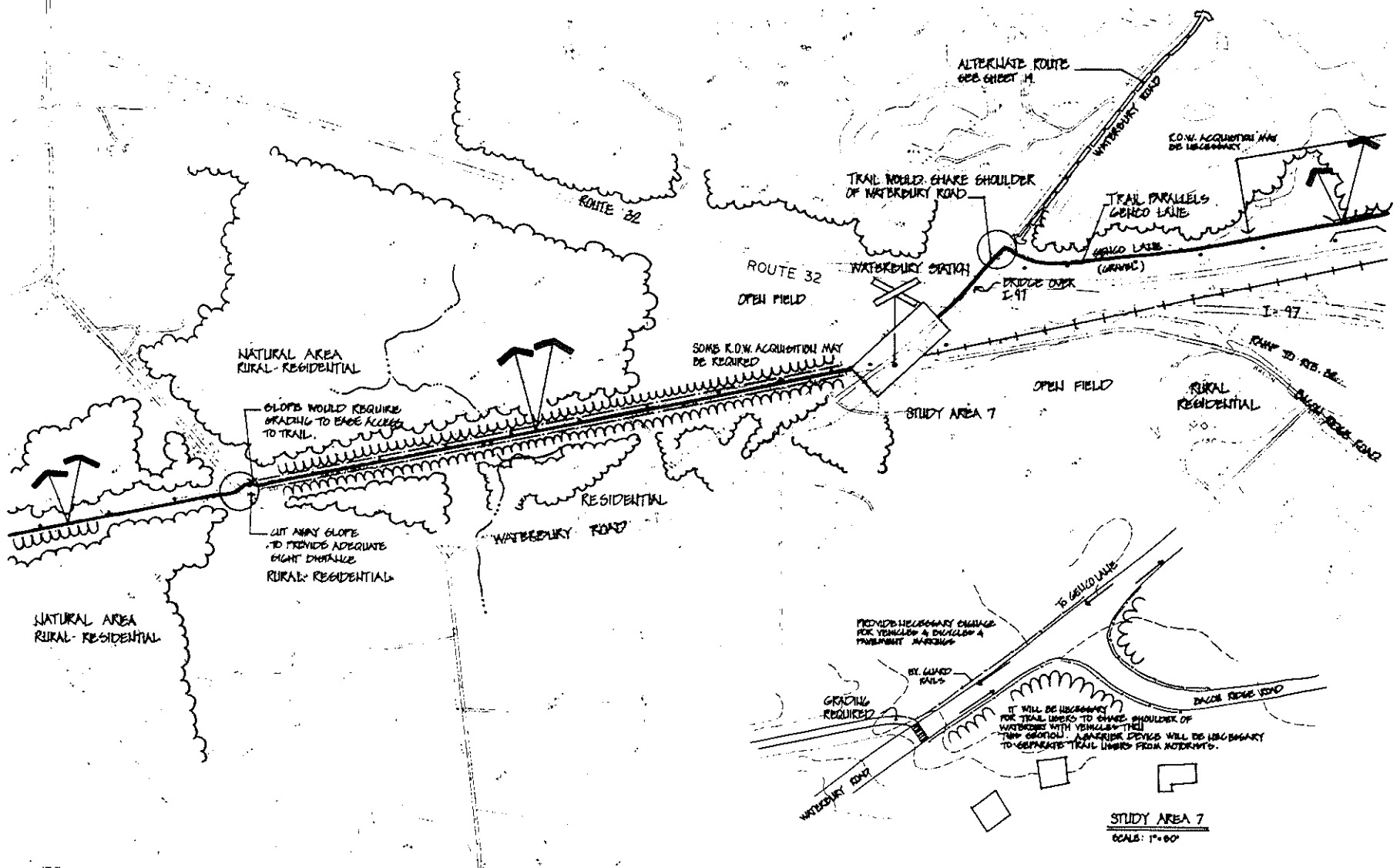

**HUMAN & ROHDE, INC.**  
 Landscape Architects  
 110 E. Pennsylvania Avenue  
 Towson, Maryland 21204  
 (301) 825-3885



ANNE ARUNDEL COUNTY				DEPARTMENT OF PUBLIC WORKS	
REVISION DATE BY	APPROVED DATE	DRAWN BY DATE	CHECKED BY DATE	SCALE SHEET NO. # OF	PROJECT NO. PROPOSAL NO.
				1" = 80'	7200 7200

WBCA TRAIL

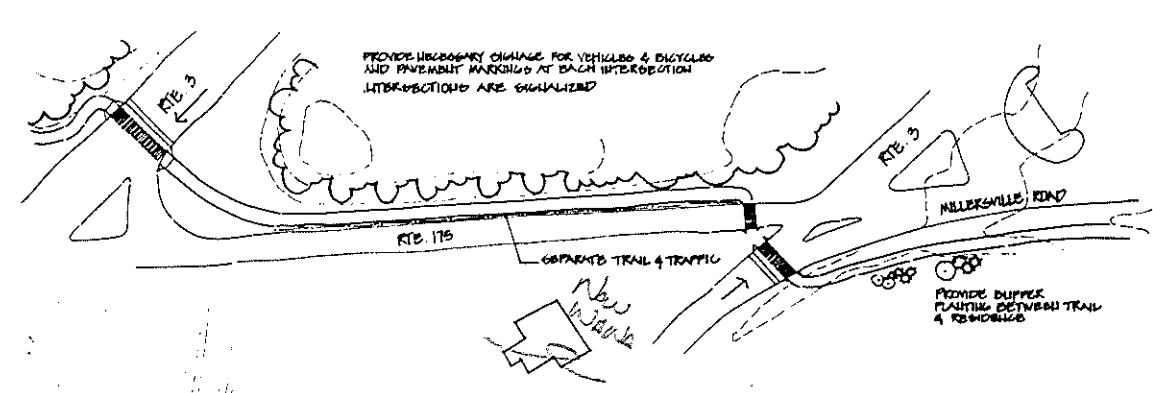

STUDY AREA 9  
SCALE: 1"=60'

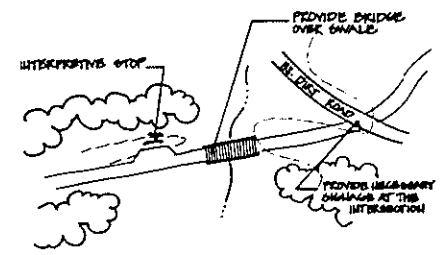

STUDY AREA 8  
SCALE: 1"=50'

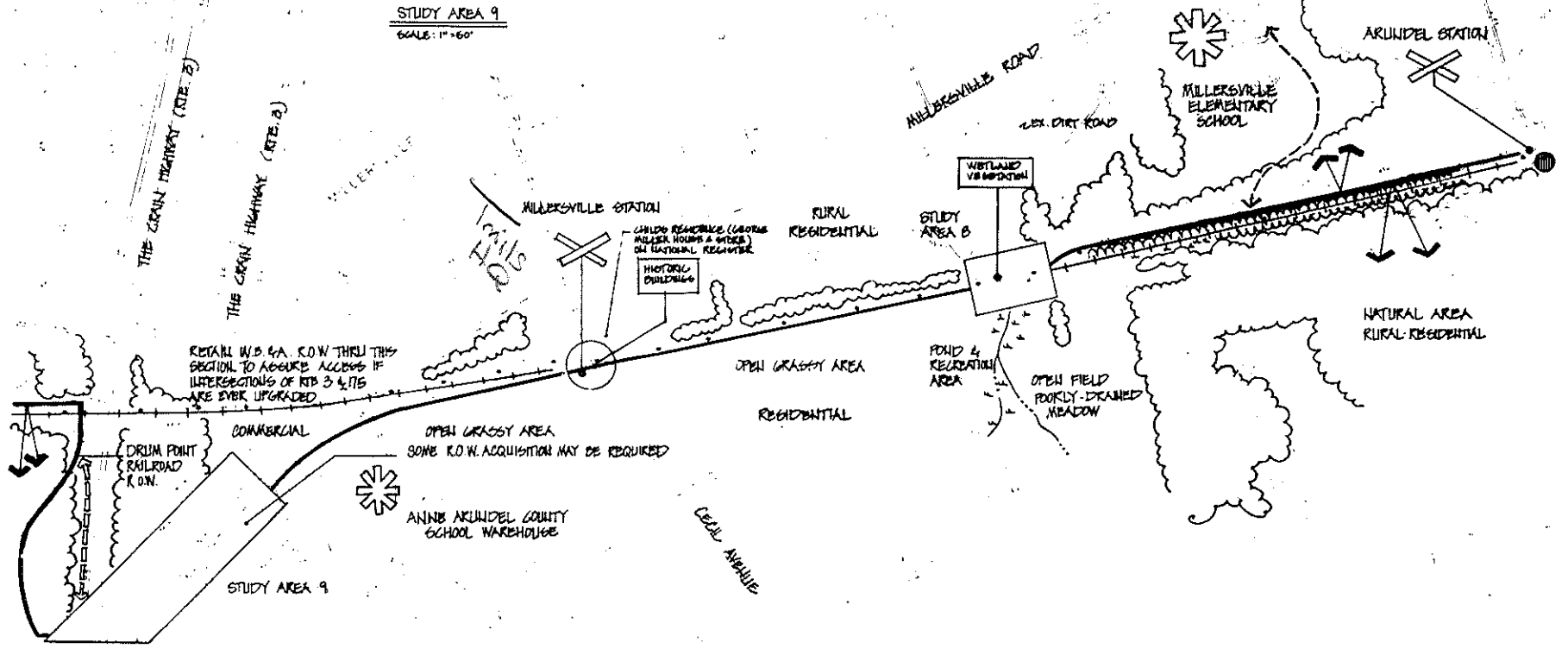

HUMAN & ROHDE, INC.  
Landscape Architects  
110 E. Pennsylvania Avenue  
Towson, Maryland 21204  
13011 825-3885



ANNE ARUNDEL COUNTY DEPARTMENT OF PUBLIC WORKS						
REVISED DATE	APPROVED BY	DATE	DRAWN BY	SCALE	SHEET NO. OF	TITLE PLAN
	WILLIAM A. ROHDE		J. W.		1 OF	WPC A TRAIL
					PROJECT NO.	
					PROPOSAL NO.	
					DATE	
					MAP NO.	

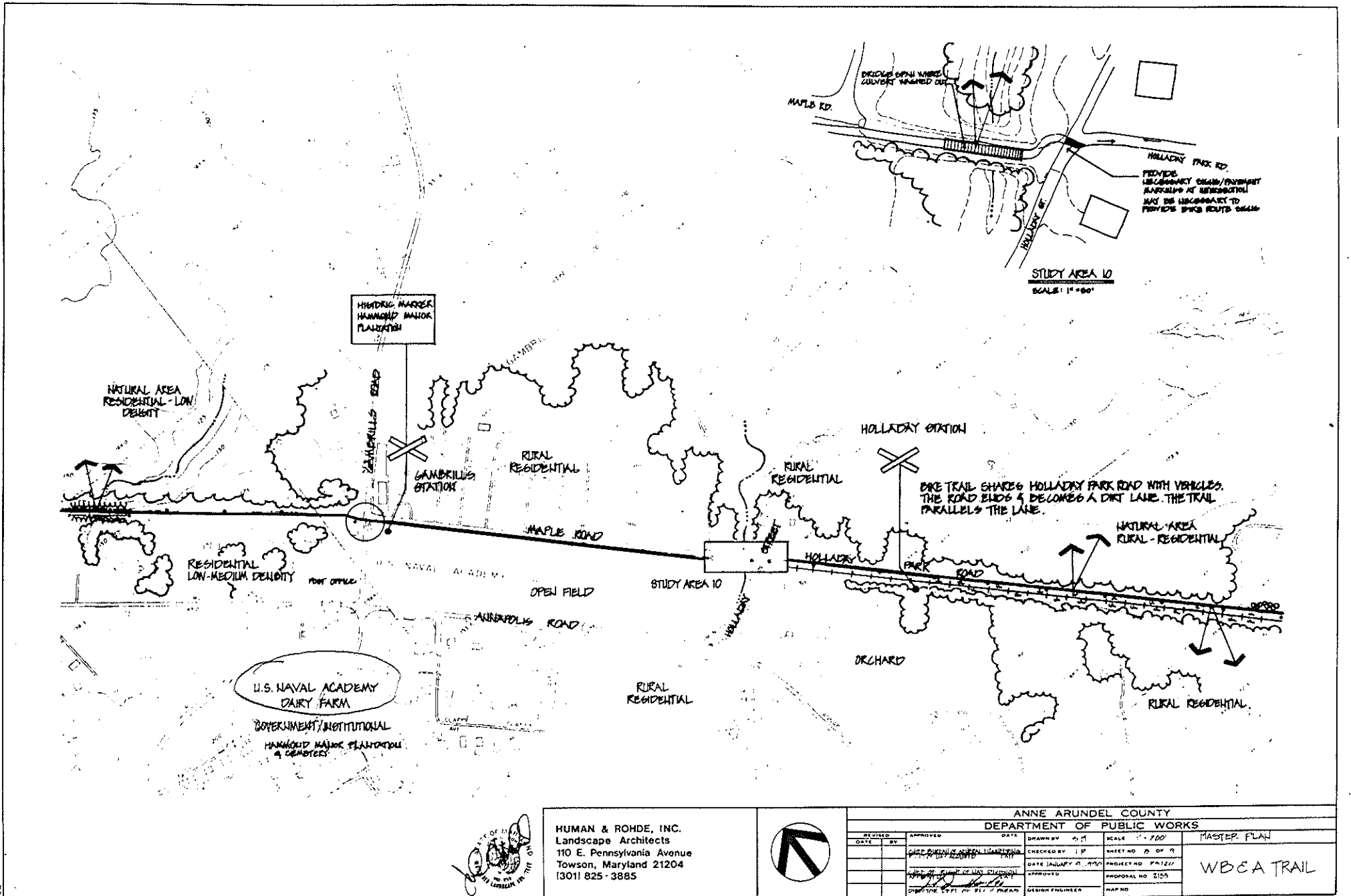

STUDY AREA 10  
SCALE: 1" = 60'

HOLLADAY STATION

DIRT TRAIL SHARES HOLLADAY PARK ROAD WITH VEHICLES. THE ROAD ENDS & BECOMES A DIRT LAINE. THE TRAIL PARALLELS THE LAINE.

PARK ROAD

RURAL RESIDENTIAL

ANNE ARUNDEL COUNTY  
DEPARTMENT OF PUBLIC WORKS

REVISION	DATE	BY	APPROVED	DATE	BY	SCALE	SHEET NO.	OF	PROJECT NO.	PROPOSAL NO.	MAP NO.
						1" = 100'	2	9	PA1221	2155	

WBCA TRAIL

HUMAN & ROHDE, INC.  
Landscape Architects  
110 E. Pennsylvania Avenue  
Towson, Maryland 21204  
(301) 825-3885



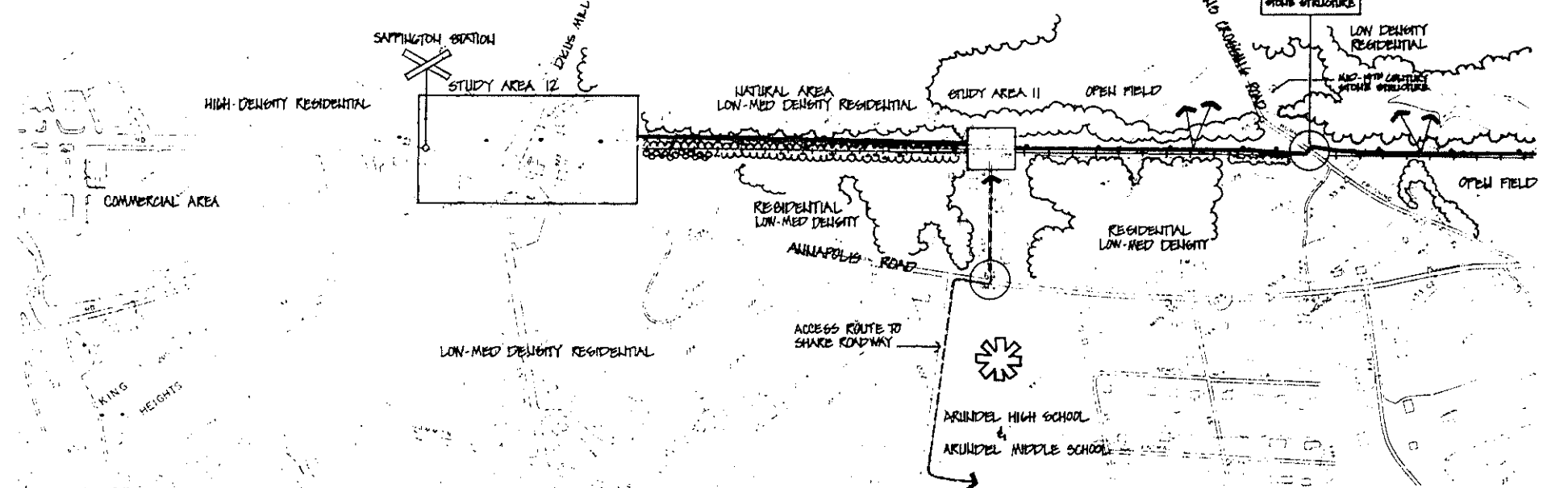
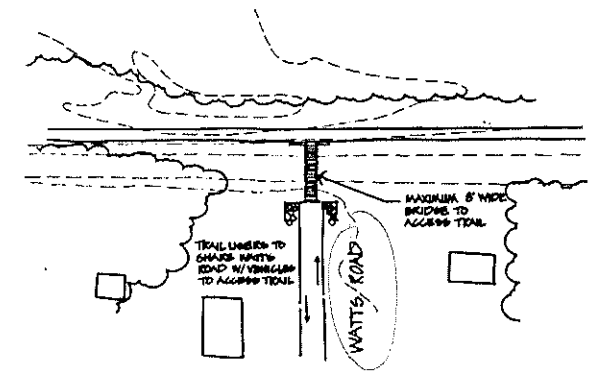
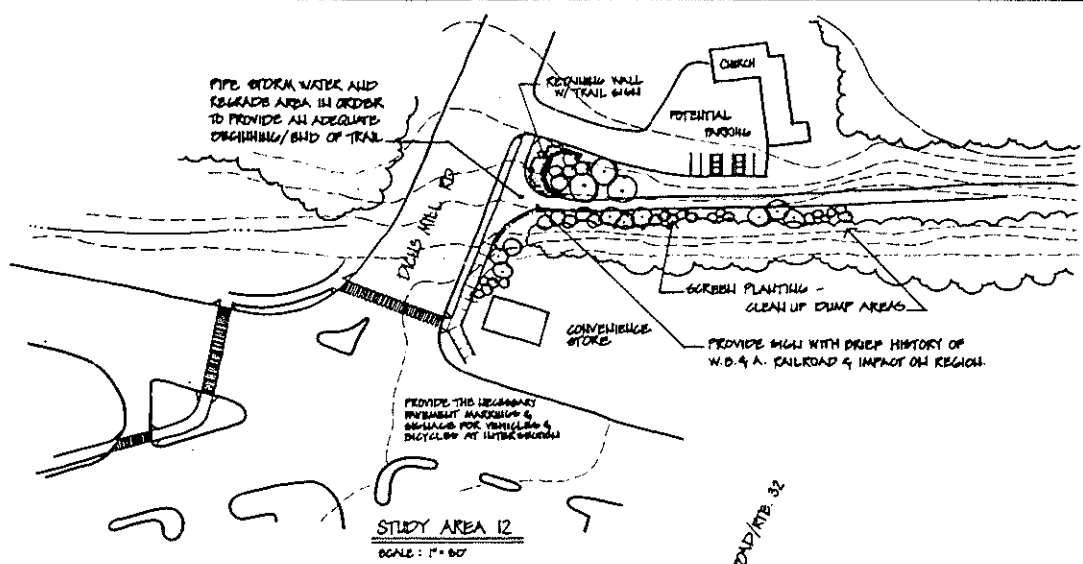

HUMAN & ROHDE, INC.  
Landscape Architects  
110 E. Pennsylvania Avenue  
Towson, Maryland 21204  
(301) 825-3885



ANNE ARUNDEL COUNTY			
DEPARTMENT OF PUBLIC WORKS			
REVIEWED	APPROVED	DATE	SCALE 1" = 200'
DATE	BY		MASTER PLAN

WBCEA TRAIL

## DEVELOPMENT IMPACT, APPROVALS & PERMITS

The construction of the WB&A Trail will have a minimum of development impact. When the trail is located on the old track bed, or utility service road, little grading will be involved. There will be additional grading at the staging areas. Construction of the trail will require a grading permit from Anne Arundel County Inspections and Permits. In addition to a grading permit, all wetlands within the WB&A right-of-way must be delineated and the delineation approved by the Baltimore District of the Corps of Engineers and the Anne Arundel County Office of Planning and Zoning.

Approvals from both the County and State will be needed because of traffic concerns, but these should be routine. The trail should be designed in close coordination with these two traffic engineering offices.

During the subdivision process of properties adjacent to the trail, developers should be encouraged to design their open space system and trails to tie into the WB&A Trail.



WB&A Trail at Epping Forest, looking north



## TECHNICAL/DESIGN CONSIDERATIONS

This chapter addresses some of the common technical/design considerations necessary for a safe and attractive trail. The WB&A Trail is a linear park, which can either be a total recreational experience or a link between two points, i.e., home and school. The trail crosses many types of terrain and land uses. Therefore, it is imperative to provide consistent treatment for stopping distances, site furniture, gates, alignments, etc. Because of the variety of environmental and manmade features, the following considerations should be taken as a guide.

### Typical Dimensions of Adult Cyclists

The following dimensions are offered as a guide for the design and engineering of the WB&A Trail. Please refer to the illustrations. The following averages can be used as references.

Average adult height on a bicycle:	7'
Average arm reach:	2'6"
Average two wheel width:	2'
Average three wheel width:	3'-4'
Average eye height:	4'-6"

Children's dimensions vary; therefore, the trail should usually be designed to the maximum adult average. However, care should be taken to provide a design which is sympathetic for children as well as adults.

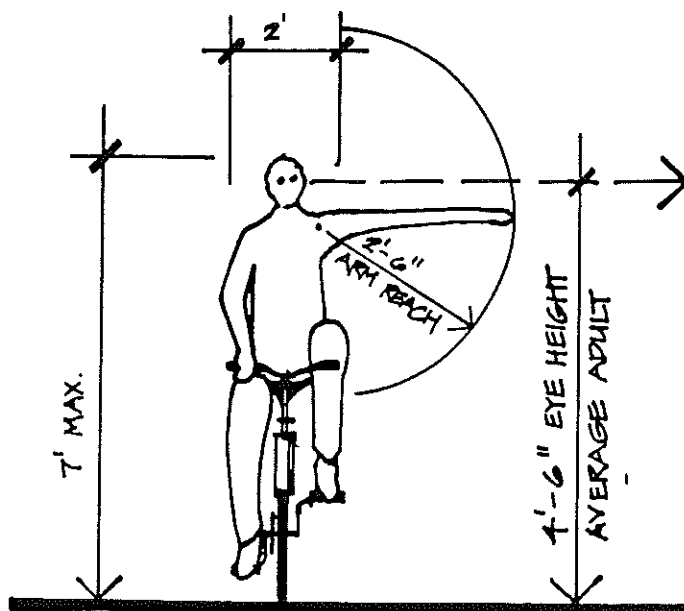

DIMENSIONS OF ADULT CYCLIST  
SCALE:  $\frac{3}{8}'' = 1'-0''$

Trail Width and Right-of-Way

These dimensions will vary depending upon the particular situation. The typical trail width shall be 10 feet. A minimum right-of-way should be no less than 15 feet with a desired width of 25 to 35 feet. In addition, the widest possible right-of-way should be established so that the trail is buffered from adjacent land use.

According to AASHTO, "a desirable minimum all paved width for a two directional bicycle path is 10 feet (3m)." Maintenance and security vehicles will be using this pavement. A narrow pavement dimension can cause pavement edge damage.

AASHTO also advises, "Under certain conditions it may be necessary or desirable to increase the width of a bicycle path to 12 feet (3.7m); for example because of substantial bicycle volume probable shared use with joggers and other pedestrians..." Steep grades and areas where cyclists will ride two abreast should also be 12 feet.

Pavement widths at staging areas, trail facilities or difficult road crossings should be a minimum of 12 feet.

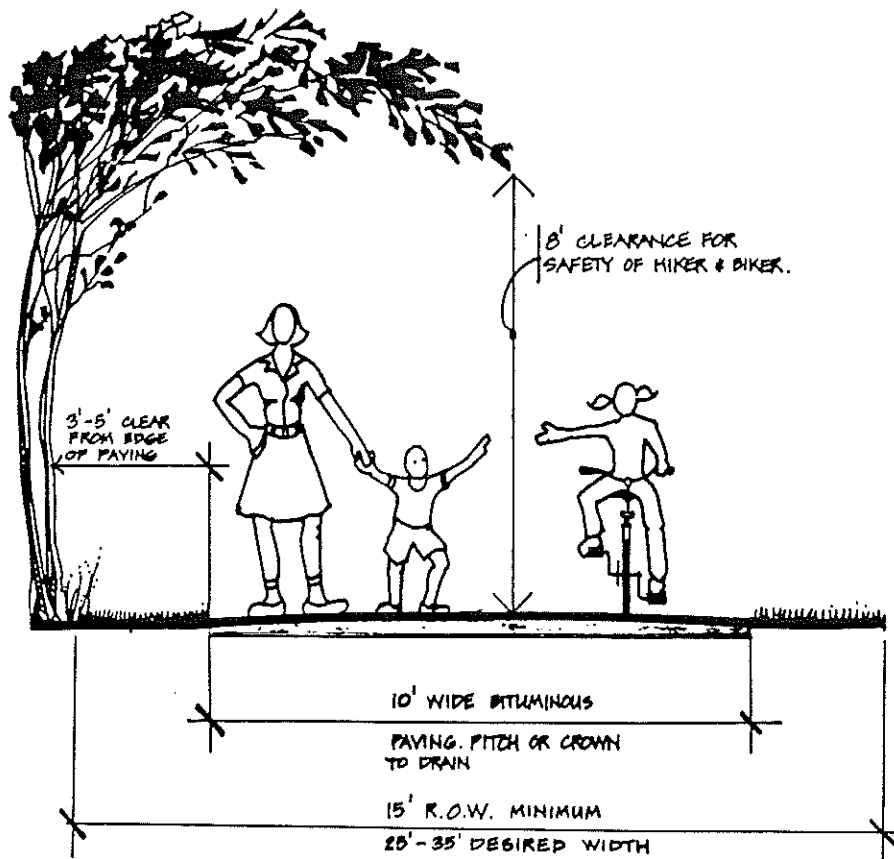

## TECHNICAL/DESIGN CONSIDERATIONS

### Design Speed, Grades

For a safe trail, AASHTO recommends that a minimum design speed of 20 mph should be used in trail design unless the grade exceeds 4 percent. The average bike speed is usually 10 to 13 miles per hour. Fortunately, the WB&A Trail was formerly graded for electric train. These trains required a minimum grade. Therefore, much of the trail would be at a 3% maximum grade, ideal for hikers and bicyclists. For new staging areas and areas not located on the original right-of-way, the grade should be no greater than 5 percent. AASHTO states, "Grades greater than 5 percent are undesirable because the ascents are difficult for many bicyclists to climb and the descents cause some bicyclists to exceed the speeds at which they are competent."

### Sight Distances

Sight distances will be much more critical for bikers along the WB&A Trail. Bicyclists have a strong desire to maintain momentum. They can be travelling at  $\pm 13$  miles an hour. At this speed, they have a greater need to see and react to each situation, i.e., an intersection, a rest area, or a gathering of pedestrians. For the safety of all trail users, AASHTO sight distance standards should be used wherever possible. The AASHTO graph below defines stopping sight distances for bicyclists at various speeds on various grades.

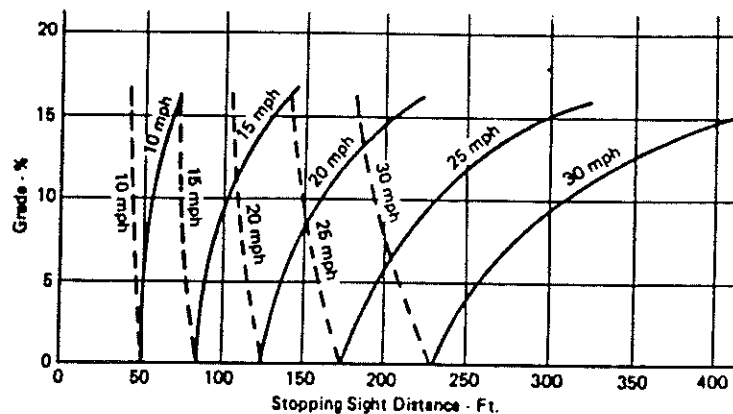

$$S = \frac{V^2}{30(f \pm G)} + 3.67 V$$

Descend (-G) ———  
Ascend (+G) - - -

Where: S = Stopping Sight Distance, Ft.  
V = Velocity, mph  
f = Coefficient of Friction (use 0.25)  
G = Grade Ft./Ft. (rise/run)

## TECHNICAL/DESIGN CONSIDERATIONS

AASHTO based the sight distance graph on a total perception and brake reaction time of 2.5 seconds. The graph also is based on a coefficient of friction of .25 (poor wet-weather braking). Please note that the WB&A Trail should be designed by the solid black line or -G. This line indicates a two way trail. For example, a cyclist travelling at 10 mph on a grade of 5% or less will require a stopping sight distance of 50 feet.

The following two graphs indicate sight distances for vertical curves and lateral clearances on horizontal curves.

### Curves

In general, all short, sharp curves should be avoided on the WB&A Trail. On such a curve, cyclists going the average 13 mph must abruptly adjust their speeds. This situation can be unsafe. Whenever possible, the curves on the WB&A Trail should be gradual.

A guide to safe bike path curve radii can be found in DeLong's Guide to Bicycles and Bicycling. Mr. DeLong recommends the following table:

Road Conditions	Radius @			
	10mph	15mph	20mph	30mph
Smooth, Dry Road (f=0.8)	9.1'	20.2	38	90
Gravel, Continuous Rain (f=0.6)	12.2	27.5	51	118
Newly Wet Road (f=0.4)	18.2	42	76	175
Sand (f=0.3)	24.5	55	98	233
Ice (f=0.1)	73	168	Better to Walk	

---

## TECHNICAL/DESIGN CONSIDERATIONS

---

This table allows for curves that are not perfect. The WB&A Trail radii should be designed between the smooth, dry road conditions and the gravel, continuous rain conditions. The WB&A Trail will be constructed with bituminous concrete. Unfortunately, trails will not be maintained to the same degree as a road surface. Therefore, the condition between dry road and wet gravel is appropriate for determining curve radii.

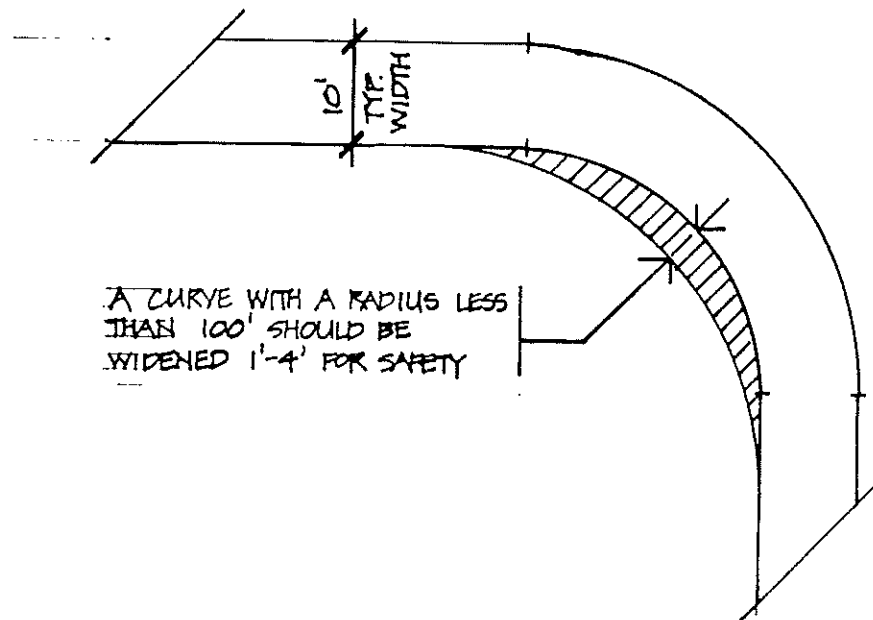

### Curve Treatment

In addition, the WB&A Trail should be widened at a different radius. The path can be widened about one to two feet to a maximum of four feet to allow greater maneuverability of a cyclist. The widened area also promotes a greater safety for both hiker and cyclist on the trail.

### Paving

In addition to hikers/bikers, the WB&A Trail will be designed for park maintenance vehicles and utility company vehicles. Most of the WB&A Trail is located along a utility company right-of-way. The paving shall be machine laid, hot mix bituminous concrete. Whenever possible, the existing track bed shall be used as the pavement base.

---

## TECHNICAL/DESIGN CONSIDERATIONS

---

Several unpaved roads and driveways cross the trail. In order to reduce the gravel that will result from passing vehicles, all unpaved roads and driveways should be paved 10 feet on both sides of the trail. This condition should be noted as a hazard and adequate brushing must be done to eliminate the unsafe condition.

If any concrete is used for the trail surface, it shall be designed to the Anne Arundel County specifications for sidewalks, curbs and handicap ramps.

### Grading & Drainage

Good drainage is essential for the WB&A Trail. Surface water must be diverted from the trail to avoid problems with standing water or the erosive force of water. The method used to drain the trail will be determined by the amount and/or speed of water and the type of soils.

Whenever possible, the WB&A Trail will be designed with a 1-3% slope to insure a simple and accurate construction of the trail. This allows the water to sheet across the trail rather than run in streams.

In some areas, the track bed has been eroded and has had standing water. In these locations, it will be necessary to either build up the trail or relocate the trail with adequate swales so that the trail drains well.

### Vegetation

The existing vegetation along the WB&A must be protected and preserved as much as possible during construction. Vegetation should be removed only for purposes of the trail construction. In some areas, the trail sits in a cut area with high slopes on both sides. Much of the existing vegetation holds the slopes and prevents erosion. The presence of scotch broom, a standard erosion control plant, indicates that erosion problems may have occurred along the trail. It is best not to disturb these slopes. If this vegetation is greatly disturbed, erosion will again result. The costs of repairing the erosion will be the responsibility of the County or the contractor.

---

## TECHNICAL/DESIGN CONSIDERATIONS

---

In addition to deterring erosion, plant materials also enhance the aesthetic, recreational experience along the trail. Therefore, during construction, good pruning practices should be maintained, i.e. branches cut flush at the limb and stems flush with the ground. For construction purposes and for future maintenance, pruning along the WB&A Trail should be selective. The pruning along the Trail should not resemble massive pruning practices of the utility companies.

### Trail Alignment

Whenever possible, the WB&A Trail will be located on the old train bed. In some areas, the WB&A Trail parallels an existing road. Unfortunately, trails located along roads can create many problems because of conflicts between motorists and hikers/bikers. In addition, locating trails along roadways increases the likelihood of wrong-way riding or walking.

When the WB&A Trail runs parallel to a road, it can become a "protected trail." A "protected trail" is one that parallels a road but is separated from vehicles by a barrier. Any number of devices can separate a trail user from a motorist. Ideally, the trail can be set back from the roadway 15-20 feet (or more) so that the setback becomes the barrier. An earth berm with plant material is best for all travellers. When a large setback is not feasible, a planted strip rather than a concrete barrier is recommended.

There are problems with a heavily "protected" trail. The WB&A Trail must not emerge from behind a planted strip at an intersection. Motorists and trail users alike must be able to see each other before an intersection. Conflicts concerning the right-of-way must be considered in the design of the trail. Both trail and roadway users should view each other for a distance determined by the sight distances of both motorist and trail cyclist. Pedestrians can stop quickly; bicyclists must have a safe stopping distance of 100-120 feet from an intersection. This distance allows a cyclist to see adjacent vehicles and helps insure a safe crossing.

## TECHNICAL/DESIGN CONSIDERATIONS

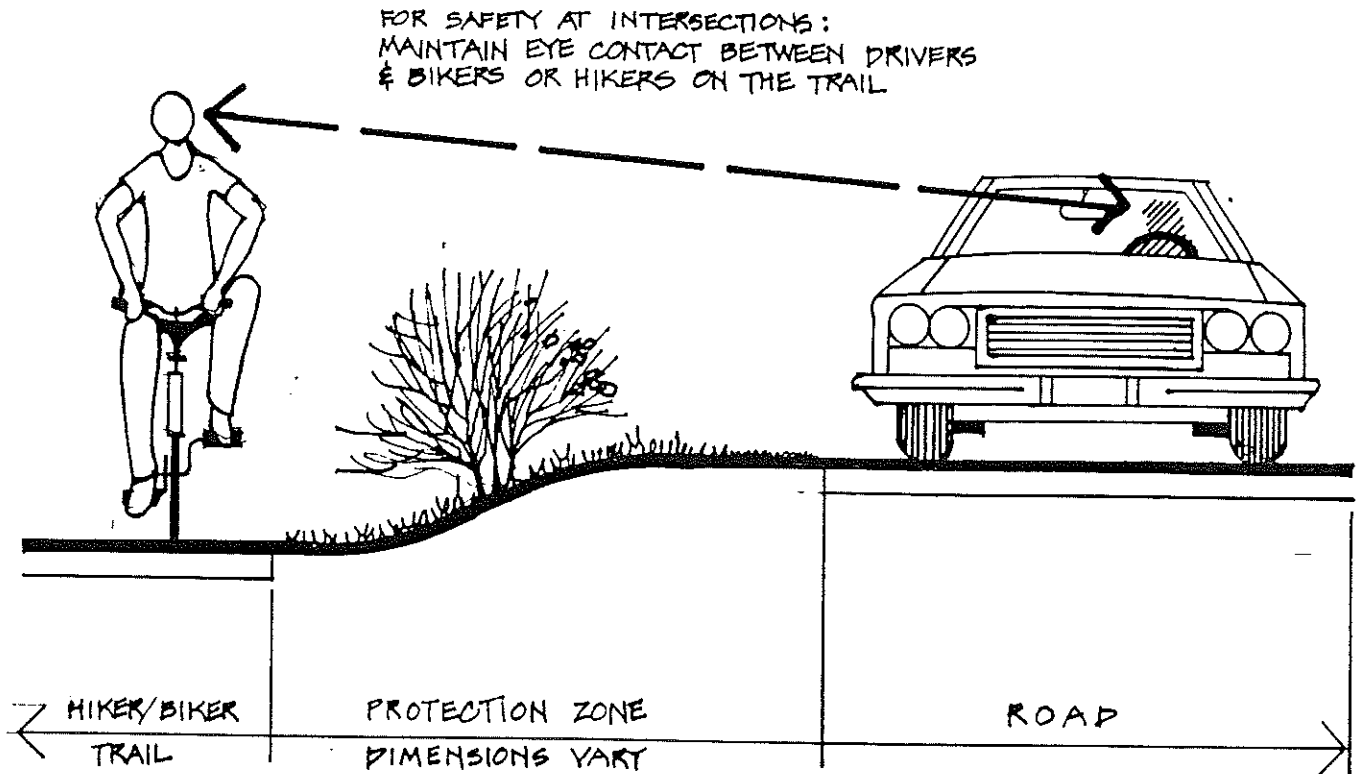

Protected Trail Treatment

### Outdoor Furniture

A consistent design of outdoor furniture should be used throughout the WB&A Trail. The outdoor furniture along the WB&A Trail will include bollards, bike racks, trash containers, light poles (at the staging areas), tables, benches and guardrails.

At this writing, much of the WB&A Trail experience is rural or rustic. Therefore, the site furniture design should reflect this character.

1. Bollards have been designed for the B&A Trail. The WB&A Trail should use the same or similar design to further enhance the link between these two trails. Removable wood bollards will allow for access by service vehicles onto the trail.
2. Light poles may be necessary at the staging areas. These poles can be made of wood with a chamfer to give it a distinctive trail style.



TECHNICAL/DESIGN CONSIDERATIONS

3. Bike racks, trash containers and tables should meet the standards used at the Department of Recreation and Parks. The trail is a linear park and the furniture should be easy to maintain and replace by the County's agency.
4. Benches can be made from two logs or salvaged stone from culverts. Log or stone benches help maintain the rural character of the WB&A Trail. Vandalism is generally not a problem with log/stone benches and they can be made more inexpensively than manufactured benches. Benches must be placed a minimum of two feet away from the edge of the pavement to insure user safety.

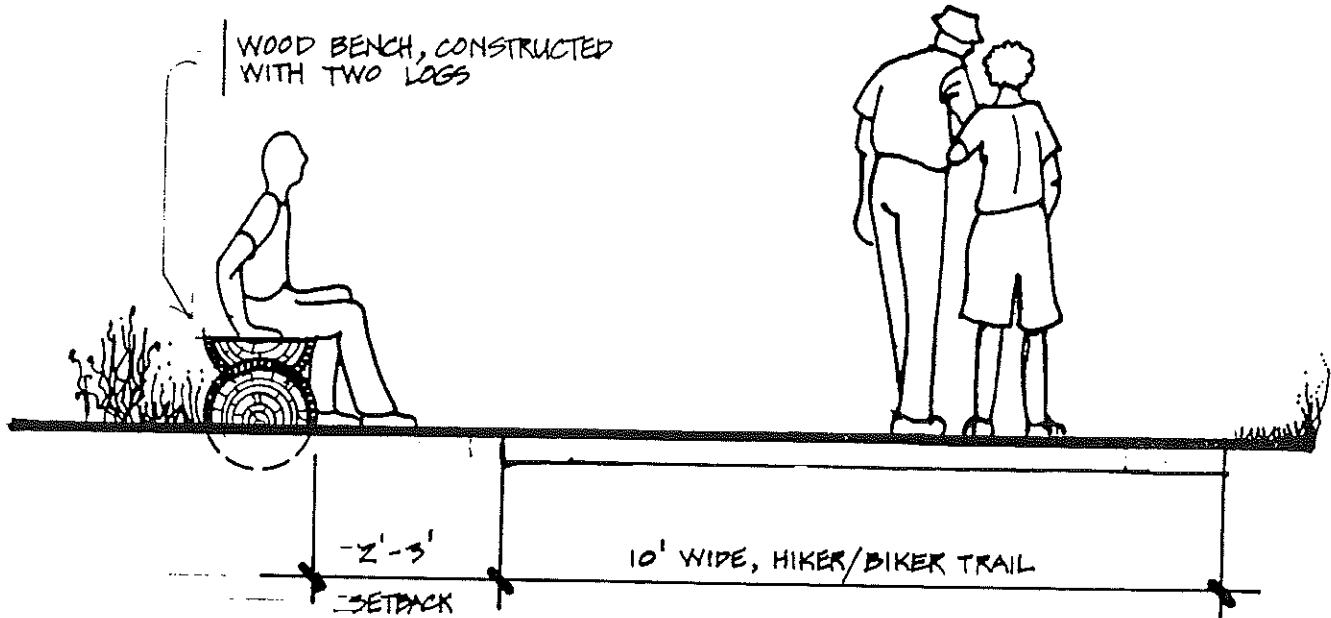

Placement of furniture along the trail

5. Guard Rails will be necessary along the trail to protect both hikers and bicyclists. Whenever possible a wood guardrail should be used to maintain the WB&A Trail character.

---

## TECHNICAL/DESIGN CONSIDERATIONS

---

These rails may be used in various locations along the trail. Guardrails should be designed for the adult cyclist's center of gravity (approximately 3' above the grade). John Williams from North Carolina's Department of Transportation wrote that "we need to design bridge guardrails with greater height. 4.5 to 5 feet is a good height to keep cyclists from sailing over." Williams remarks that if a cyclist is forced against a lower bridge rail, "he or she tends to catapult over the rail, rather than bounce off."

In less hazardous situations, such as scenic overlooks, a rail height of 3 feet may be used. In special use areas, such as scenic overlooks, a simple metal pipe rail may be used. It can retain the rustic character yet allow for greater views and it is more transparent than a double rail guardrail.

### Signs

There will be different types of signs which can occur along the WB&A Trail. These are the six major types of signs:

1. Staging Area Sign(s), located at both ends of the trail. The name of the trail, location map, destination, distances, trail rules and historic significance should be included.
2. Directional Signs, should be used where paths can be confused (i.e. road intersections). Directional signs may also show destinations adjacent to the trail. Distances may also be given in miles and kilometers on directional signs.
3. Warning Signs, must be placed on the trail to indicate hazardous conditions such as a road intersection. Warning signs should be placed approximately 100-120 feet in front of any hazard.
4. Regulatory Signs, are STOP or YIELD signs. The state standard for colors should be followed. These signs should be smaller than roadway signs. Regulatory signs may need to be installed on trail gates (i.e. no dogs, no motorcycles).
5. Information Signs, should be used to indicate mileage markers, emergency services, rest areas, historic train stations, etc.

---

## TECHNICAL/DESIGN CONSIDERATIONS

---

6. Night Visibility Signs, reflecting strips and reflective paint on bollards, gates and other hazards should be part of the trail.

To maintain a consistency along Anne Arundel County bike trails, the signage should conform to Anne Arundel County Standards and project the same image as the signage along the B&A Trail.

The following aesthetic characteristics should be considered:

1. Sign Material should be made of wood. This material is the most compatible with the natural environment. It is also the most cost effective.
2. Sign Sizes should be standardized.
3. Sign Colors should be designed for the entire trail.
4. Sign Letter Style should be consistent throughout the trail. Letters can be sand blasted or routed into wood and then painted. The same type of letters should be used on all trail signs.
5. Sign Location should take into account the existing vegetation and grades. Safe sight distances should always be maintained. Height of a sign is generally 40" from grade to the bottom of a sign. For safety, the sign should be located on the shoulder with a 2' clear shoulder.
6. Sign Consolidation is recommended whenever possible. Use signs sparingly. However, warning and regulatory signs shall not be mixed with any other type of sign.
7. Pavement Signs should be considered. STOP signs as well as directional and informational signs can be painted on the pavement.



WB&A Trail at MD Rte 178 and Dunton Road

## ADMINISTRATION OF THE TRAIL

The WB&A trail will require all of the normal maintenance and upkeep of a county park.

The average WB&A right-of-way is 66 feet and is occupied principally by Baltimore Gas & Electric Company. BG&E is maintaining the entire right-of-way. The trail, including slopes, benches and signs, will require approximately 20 feet and the County will be responsible for that portion of the maintenance.

### 1. Maintenance

Landscape maintenance will be needed for pruning trees/shrubs along the trail. Well-used areas (i.e. at the beginning/end of trail or overlooks) will need refurbishing and seasonal upkeep. General maintenance for removal of refuse will be needed. Potholes along the trail must be filled as these represent a hazard for cyclists. The County should encourage and coordinate environmental organizations, and hiking clubs, such as Volksmarch and Scout troops (girls and boys), to provide clean-up activities.

### 2. Recreational Opportunities

The Anne Arundel Department of Recreation & Parks will be the County agency to manage the trail. Various hikes, such as wildflower walks or history walks, and cycling activities can be scheduled for the WB&A trail.

### 3. User Assistance

In addition to special seasonal/feature activities, the Department of Recreation and Parks should provide assistance to the hiker/biker if any problem arises on the trail. Problems may range from loose and threatening dogs to a large fallen branch blocking the trail. It must be convenient for the WB&A trail user to bring problems to the attention of the appropriate County agency.

4. Right-of-Way Rights

If possible, the County should maintain the WB&A's subsurface rights. If additional cables, water, sewer or gas need to pass under the trail, the County may consider leasing these rights for the purpose of generating revenues for the management of the trail. Future development will mean increased useage, thereby increasing maintenance costs or requiring new road crossing design. There should be no leasing of air rights for private development.

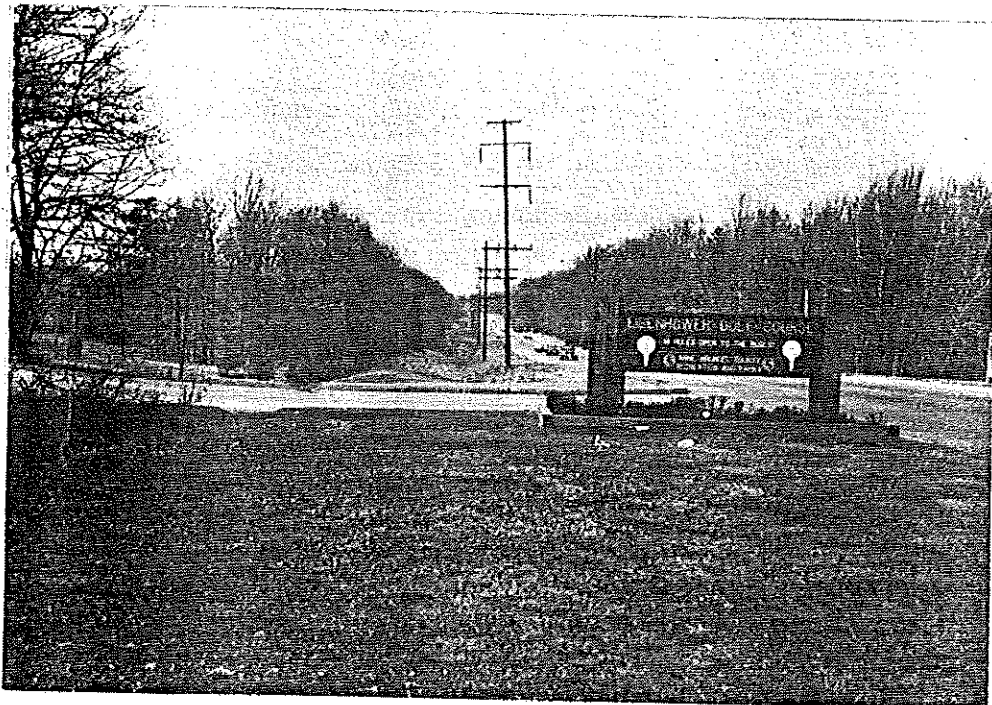

WB&A Trail, adjacent to Eisenhower Golf Course

---

PROJECT PHASING

---

- Phase I: Waterbury at Bacon Ridge Road to Maryland Route 3 (The Crain Highway) approx. 2.0 miles
- Phase II: Maryland Route 3 (The Crain Highway) to Maryland Route 32 (Dicus Mill Road) approx. 2.3 miles
- Phase III: Bestgate Mall to The Dwight D. Eisenhower Golf Course approx. 2.6 miles
- Phase IV: The Dwight D. Eisenhower Golf Course to Waterbury Road approx. 3.4 miles

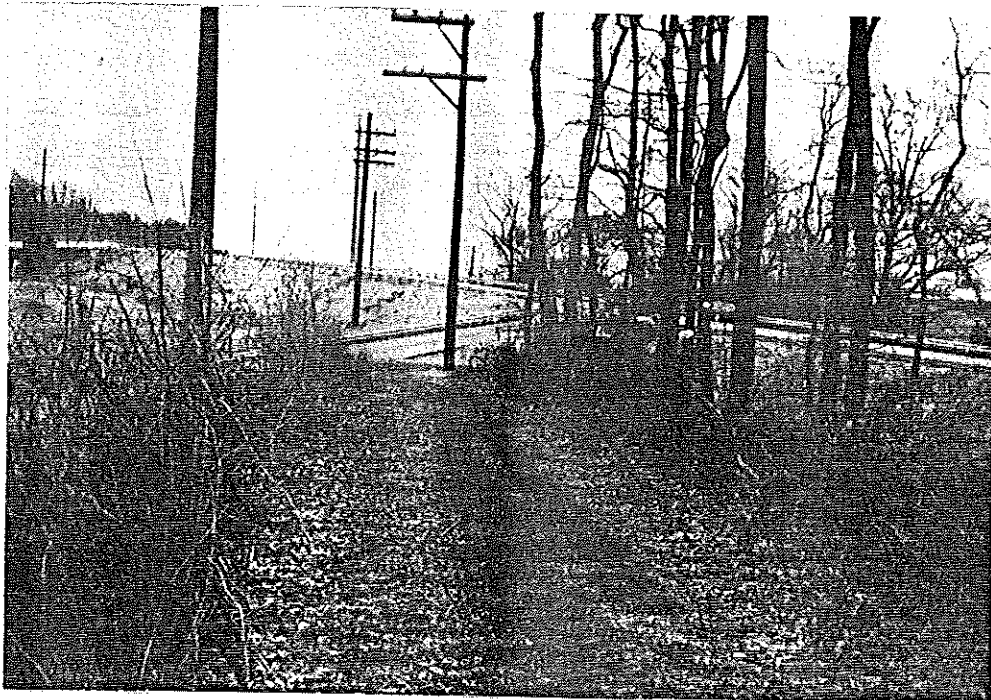

Beginning of Phase I -  
Waterbury at Bacon Ridge Road

---

---

COST ESTIMATE

---

PHASE I: WATERBURY AND BACON RIDGE ROAD  
TO MARYLAND ROUTE 3

<u>Site Engineering</u>		
Lump Sum		\$ 5,000
<u>Demolition</u>		
Fence Removal		
Lump Sum		\$ 500
<u>Sediment Control</u>		
Lump Sum		\$ 5,000
<u>Clear &amp; Grub</u>		
Lump Sum		\$ 5,000
<u>Grading</u>		
Lump Sum		\$ 50,000
<u>Paving</u>		
4" Asphalt w/4" Stone Base		
11,500 sy @ \$20.00/sy		\$230,000
<u>Guardrail</u>		
Wood Guardrail		
7100 lf @ \$25.00/lf		\$177,500
<u>Bridge</u>		
30 Ft. Span		
1 @ \$11,000.00		\$ 11,000
<u>Planting</u>		
Lump Sum		\$ 5,000
<u>Signage</u>		
Traffic Sign		
28 @ \$300.00/ea.		\$ 8,400
Pavement Marking		
Lump Sum		\$ 1,200
Interpretive Sign		
2 @ \$500.00/ea.		\$ 1,000
Station Marker		
3 @ \$500.00/ea.		\$ 1,500
<u>Site Amenities</u>		
Wood Bollards 6"x6"x36" high		
22 @ \$120.00/ea.		\$ 2,640
Removable Wood Bollard		
11 @ \$250.00/ea.		\$ 2,750



Trash Receptacie		
2 @ \$200.00/ea.	\$	400
Picnic Table		
6' long redwood/cedar		
2 @ \$1200.00/ea.	\$	2,400
Bench		
1 @ \$700.00/ea.	\$	700
<u>Drainage (From Drainage Study)</u>		
Lump Sum		\$119,800
<u>Design Services</u>		
Lump Sum	\$	63,000
<u>Inspection Services</u>		
Lump Sum	\$	<u>63,00</u>
	TOTAL	\$755,790
	SAY	\$756,000

NOTE: Land acquisition costs have not been included.  
All prices are based upon 1989 costs.

---

---

COST ESTIMATE

---

---

PHASE II: MARYLAND ROUTE 3 TO  
ROUTE 32 (DICUS MILL ROAD)

<u>Site Engineering</u>		
Lump Sum	\$	5,000
<u>Demolition</u>		
Remove Curb		
Lump Sum	\$	5,000
<u>Sediment Control</u>		
Lump Sum	\$	6,000
<u>Clear &amp; Grub</u>		
Lump Sum	\$	7,000
<u>Grading</u>		
Lump Sum	\$	65,500
<u>Paving</u>		
4" Asphalt w/4" Stone Base		
13,585 sy @ \$20.00/sy	\$	271,700
5" Concrete Walk		
2640 sf @ \$6.00/sf	\$	15,840
<u>Guardrail</u>		
Wood Guardrail		
1080 lf @ \$25.00/lf	\$	27,000
<u>Bridge/Pipe</u>		
30' span		
2 @ \$11,000.00/ea.	\$	22,000
15" pipe		
4 ea. .- 15 lf @ \$50.00/lf	\$	3,000
24" pipe		
1 - 15 lf @ \$100.00/lf	\$	1,500
24" pipe		
1 - 30 lf @ \$100.00/lf	\$	3,000
<u>Retaining Wall</u>		
Lump Sum	\$	14,400
<u>Planting</u>		
Lump Sum	\$	5,000

<u>Signage</u>		
Traffic Sign		
30 @ \$300.00/ea.	\$	9,000
Pavement Marking		
Lump Sum	\$	3,600
Station Marker		
2 @ 500.00/ea.	\$	1,000
Trail Sign		
Lump Sum	\$	5,000
<u>Pedestrian Bridge over Rt 3</u>		
2 @ \$1,000.000/ea.	\$2,000.000	
<u>Site Amenities</u>		
Wood Bollards 6"x6"x36" high		
22 @ \$120.00/ea.	\$	2,640
Removable Wood Bollard		
11 @ \$250.00/ea.	\$	2,750
Trash Receptacle		
3 @ \$200.00/ea.	\$	600
Bench		
2 @ \$700.00/ea.	\$	1,400
<u>Drainage (From Drainage Study)</u>		
Lump Sum	\$	261,300
<u>Design Services</u>		
Lump Sum	\$	75,000
<u>Inspection Services</u>		\$ 75,000
	TOTAL	\$2,889,230
	SAY	\$2,890,000

NOTE: Land acquisition costs have not been included.  
All prices are based on 1989 costs.

---

---

COST ESTIMATE

---

PHASE III: BESTGATE MALL TO  
THE DWIGHT D. EISENHOWER GOLF COURSE

<u>Site Engineering</u>		
Lump Sum		\$ 5,000
<u>Demolition</u>		
Curb Removal		
Lump Sum		\$ 5,000
<u>Sediment Control</u>		
Lump Sum		\$ 6,000
<u>Clear &amp; Grub</u>		
Lump Sum		\$ 4,000
<u>Grading</u>		
Lump Sum		\$ 70,000
<u>Paving</u>		
4" Asphalt w/4" Stone Base		
15,255 sy @ \$20.00/sy		\$305,100
<u>Guardrail</u>		
Wood Guardrail		
2120 lf @ \$25.00/lf		\$ 53,000
<u>Bridge/Pipe</u>		
15" Pipe		
8 ea. - 15 lf @ \$50.00/lf		\$ 6,000
<u>Planting</u>		
Lump Sum		\$ 28,000
<u>Signage</u>		
Traffic Sign		
37 @ \$300.00/ea.		\$ 11,100
Pavement Marking		
Lump Sum		\$ 3,200
Interpretive Sign		
3 @ \$500.00/ea.		\$ 1,500
Station Marker		
3 @ \$500.00/ea.		\$ 1,500
Trail Sign		
Lump Sum (Entrance)		\$ 5,000

Site Amenities

Wood Bollards 6"x6"x36" high 40 @ \$120.00/ea.	\$ 4,800
Removable Wood Bollard 20 @ \$250.00/ea.	\$ 5,000
Trash Receptacle 5 @ \$200.00/ea.	\$ 1,000
Bench 1 @ \$700.00/ea.	\$ 700
Picnic Table 6' long redwood/cedar 6 @ \$1200.00/ea.	\$ 7,200
Bike Rack 3 @ \$600.00/ea.	\$ 1,800
Comfort Station Lump Sum	\$100,000

Drainage (From Drainage Study)

Lump Sum \$146,900

Design Services

Lump Sum \$ 77,000

Inspection Services

Lump Sum \$ 77,000

TOTAL \$925,800

SAY \$926,000

NOTE: Land acquisition costs have not been included.  
All prices are based on 1989 costs.

---

---

COST ESTIMATE

---

PHASE IV: EISENHOWER GOLF COURSE  
TO WATERBURY ROAD

<u>Site Engineering</u>		
Lump Sum		\$ 5,000
<u>Demolition</u>		
Curb Removal		
Lump Sum		\$ 3,000
Remove Existing Walk		
150 sy @ \$5.00/sy		\$ 750
<u>Sediment Control</u>		
Lump Sum		\$ 8,000
<u>Clear &amp; Grub</u>		
Lump Sum		\$ 6,000
<u>Grading</u>		
Lump Sum		\$175,000
<u>Paving</u>		
4" Asphalt w/4" Stone Base		
20,011 sy @ \$20.00/sy		\$400,200
5" Concrete Walk		
1350 sf @ \$6.00/sf		\$ 8,100
<u>Guardrail</u>		
Wood Guardrail		
1250 lf @ \$25.00/lf		\$ 31,250
<u>Bridge/Pipe</u>		
15" Pipe		
8 ea. - 15 lf @ \$50.00/lf		\$ 6,000
Pipe		
Lump Sum		\$ 15,000
<u>Planting</u>		
Lump Sum		\$ 30,000
<u>Signage</u>		
Traffic Sign		
24 @ \$300.00/ea.		\$ 7,200
Pavement Marking		
Lump Sum		\$ 3,600
Interpretive Sign		
2 @ \$500.00/ea.		\$ 1,000

Station Marker		
3 @ \$500.00/ea.		\$ 1,500
<u>Site Amenities</u>		
Wood Bollards 6"x6"x36" high		
28 @ \$120.00/ea.		\$ 3,360
Removable Wood Bollard		
14 @ \$250.00/ea.		\$ 3,500
Trash Receptacle		
3 @ \$200.00/ea.		\$ 600
Bench		
3 @ \$700.00/ea.		\$ 2,100
<u>Drainage (From Drainage Study)</u>		
Lump Sum		\$443,800
<u>Design Services</u>		
Lump Sum		\$116,000
<u>Inspection Services</u>		
Lump Sum		\$116,000
	TOTAL	\$1,386,960
	SAY	\$1,400,000

NOTE: Land acquisition costs have not been included.  
All prices are based on 1989 costs.

---

## BIBLIOGRAPHY

---

Wagner, Charles M. A Pictorial History of the Washington Baltimore & Annapolis Electric Railroad, Bulletin No. 1. Washington D.C.: Washington Electric Railway Historical Society Inc., 1951.

Warren, Marlon E. & Mary E. Annapolis Portrait - The Train's Done Been and Gone. Boston: Godine, 1976.

White, Roger B. "The WB&A: A Short Outline of the Short Line." Quarterly Bulletin of Anne Arundel County Historical Society, April 1974.

### TECHNICAL PUBLICATIONS AND BOOKS:

American Association of State Highway and Transportation Officials. Guide for Development of New Bicycle Facilities, a report. Washington, D.C., 1981.

Bicycle Federation of American & Bikecentennial. "Bicycling Reference Book." Cycline News Service, 1988 edition.

The Coalition for the Capital Crescent Trail and Greater Bethesda-Chevy Chase Coalition. Concept Plan for the Capital Crescent Trail. December 1988.

DeLong, Fred. DeLong's Guide to Bicycles and Bicycling: The Art and Science. Radnor, PA: Chilton 1978.

Federal Highway Administration, Offices of Research & Development. Highway Route Designation Criteria for Bicycle Routes. Report No. FHWA-RD-86/066. Springfield, VA., National Technical Information Services. April 1986.

Gouin, Clara L. "Trail Through Time: Proposed Plan for Potomac Heritage National Scenic Trail in Prince George's County." Masters thesis, Morgan State University, 1987.

Harris, Charles W.; Dines, Nicholas T. Time-Saver Standards for Landscape Architecture. Mc-Graw-Hill, 1988.

Jarrell, Temple R. Bikeways, Design-Construction-Programs. National Recreation and Park Association, 1974.



---

## BIBLIOGRAPHY

---

Olson, Jana; Hom, Hanson. A Trail Manual for the East Bay Regional Park District. 5 October 1976.

Peek/Smith, Inc. Development Guideline for the B&A Trail. Department of Recreation & Parks, Anne Arundel County, MD.

U.S. Dept. of Natural Resources. Living Along Trail, What People Expect and Find, a report. Saint Paul, MN.: 9 September 1980.

Williams, John. Some Myths and Errors in the Field of Bicycle Facility and Program Development. North Carolina: Department of Transportation Bicycle Program. Fall 1979.

