

DEPRESSED CURB FOR DRIVEWAY/ENTRANCE

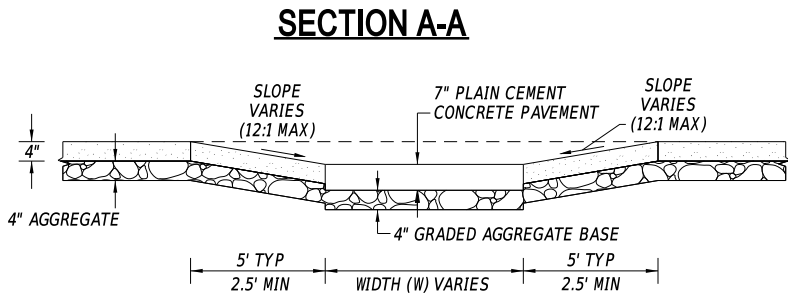

SECTION B-B

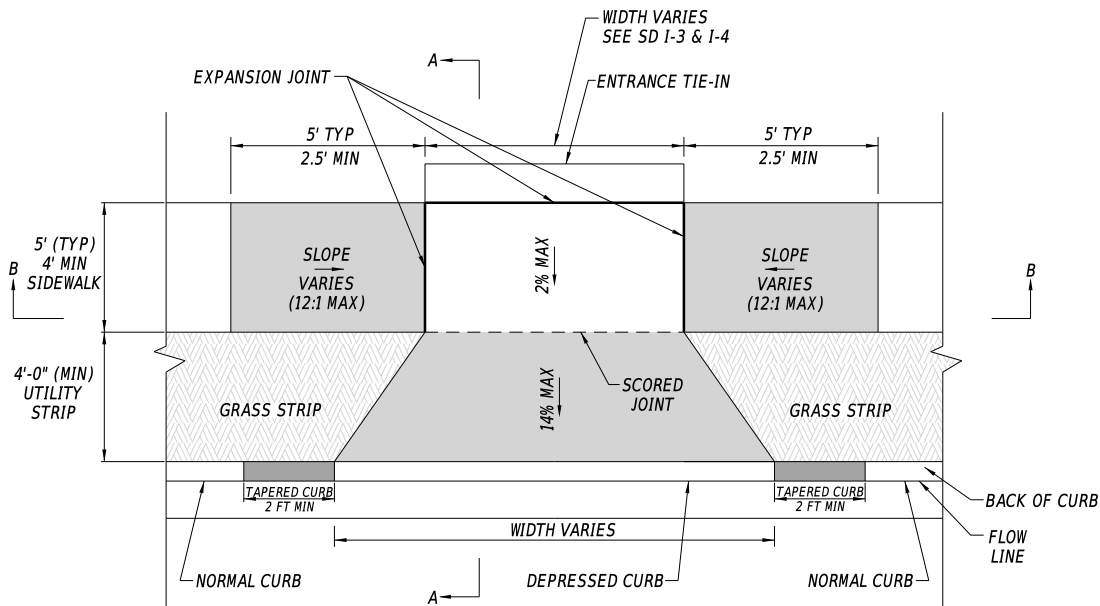

PLAN

NOTES:

1. FOR USE IN AREAS WHERE THERE IS SIDEWALK SEPARATED FROM THE CURB BY A BUFFER (UTILITY STRIP) OR WHERE IT IS EXPECTED THAT SIDEWALK WILL BE ADDED IN THE FUTURE.
2. WHEN AN EXISTING ENTRANCE IS LESS THAN THE MINIMUM WIDTH, A UNIFORM TAPER SHALL BE CONSTRUCTED TO TIE INTO THE EXISTING ENTRANCE AS DIRECTED BY THE ENGINEER.
3. EXPANSION JOINT MATERIAL TO BE INSTALLED IN ACCORDANCE WITH PED. FAC. STD. DETAIL PF-27 - SIDEWALK JOINTS.
4. WHERE 60" SIDEWALK CAN NOT BE PROVIDED, 48" MIN. MAY BE USED WHERE PASSING ZONES ARE PROVIDED IN ACCORDANCE WITH PED. FAC. STD. DETAIL PF-26 - SIDEWALK PASSING ZONES.
5. CURB AND COMBINATION CURB AND GUTTER SHALL BE DEPRESSED AS SHOWN ABOVE. PAYMENT FOR DEPRESSING THE CURB SHALL BE INCIDENTAL TO THE PRICE OF THE SPECIFIED CURB.
6. TRANSITION PANELS TO TIE INTO EXISTING SIDEWALK SHALL BE INSTALLED IN ACCORDANCE WITH PED. FAC. STD. DETAIL PF-28 - SIDEWALK TRANSITION PANEL.

LEGEND	
	LANDING/TURNING SPACE SEE ADA NOTES C-2
	RAMP SURFACE SEE ADA NOTES C-1
	TAPERED CURB SEE ADA NOTES C-3
	DETECTABLE WARNING SURFACE SEE ADA NOTES D-1

ANNE ARUNDEL COUNTY DEPARTMENT OF PUBLIC WORKS	APPROVED	STANDARD ROADWAY AND SITE IMPROVEMENT DETAILS ADA DRIVEWAY/ENTRANCE RAMPED - WITH BUFFER	REVISED
	_____ CHIEF ENGINEER		1
	_____ DESIGN ENGINEER		5A
	DATE:		

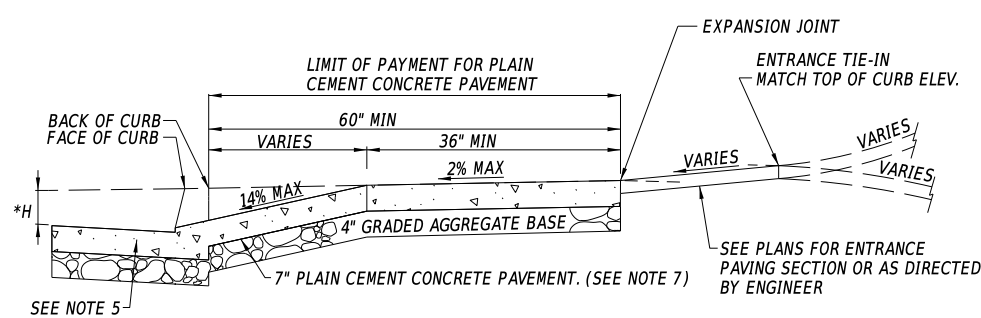
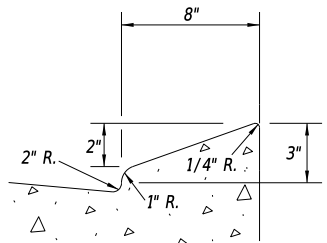
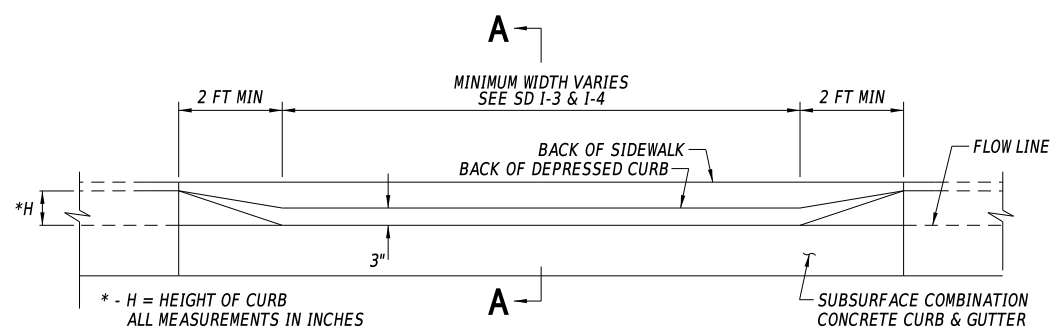
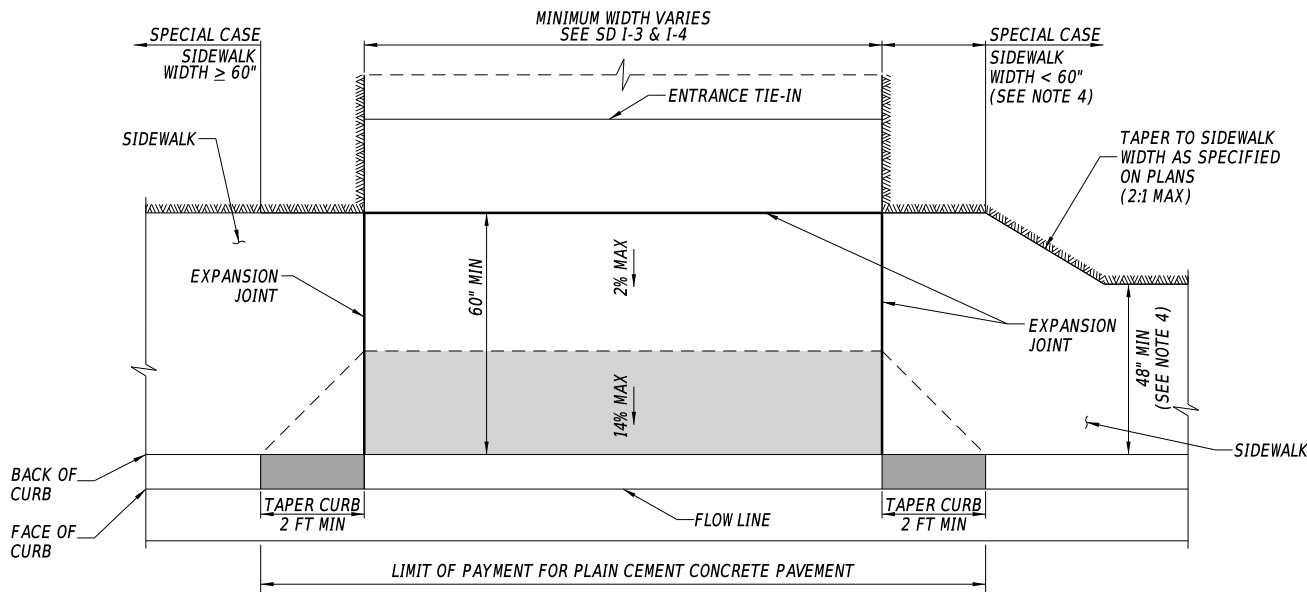

DEPRESSED CURB FOR DRIVEWAY/ENTRANCE

NOTES:

- FOR USE IN AREAS WHERE THERE IS SIDEWALK ADJACENT TO THE BACK OF CURB OR WHERE IT IS EXPECTED THAT SIDEWALK WILL BE ADDED IN THE FUTURE.
- WHEN AN EXISTING ENTRANCE IS LESS THAN THE MINIMUM WIDTH, A UNIFORM TAPER SHALL BE CONSTRUCTED TO TIE INTO THE EXISTING ENTRANCE AS DIRECTED BY THE ENGINEER.
- EXPANSION JOINT MATERIAL TO BE INSTALLED IN ACCORDANCE WITH PED. FAC. STD. DETAIL PF-27 - SIDEWALK JOINTS.
- WHERE 60" SIDEWALK CAN NOT BE PROVIDED, 48" MIN. MAY BE USED WHERE PASSING ZONES ARE PROVIDED IN ACCORDANCE WITH PED. FAC. STD. DETAIL PF-26 - SIDEWALK PASSING ZONES.
- CURB AND COMBINATION CURB AND GUTTER SHALL BE DEPRESSED AS SHOWN ABOVE. PAYMENT FOR DEPRESSING THE CURB SHALL BE INCIDENTAL TO THE PRICE OF THE SPECIFIED CURB.
- TRANSITION PANELS TO TIE INTO EXISTING SIDEWALK SHALL BE INSTALLED IN ACCORDANCE WITH PED. FAC. STD. DETAIL PF-28 - SIDEWALK TRANSITION PANEL

LEGEND	
	LANDING/TURNING SPACE SEE ADA NOTES C-2
	RAMP SURFACE SEE ADA NOTES C-1
	TAPERED CURB SEE ADA NOTES C-3
	DETECTABLE WARNING SURFACE SEE ADA NOTES D-1

ANNE ARUNDEL COUNTY DEPARTMENT OF PUBLIC WORKS	APPROVED	STANDARD ROADWAY AND SITE IMPROVEMENT DETAILS	REVISED	1 5B
	CHIEF ENGINEER			
	DESIGN ENGINEER	ADA DRIVEWAY/ENTRANCE 5 FT MIN APRON - NO BUFFER		
	DATE:			

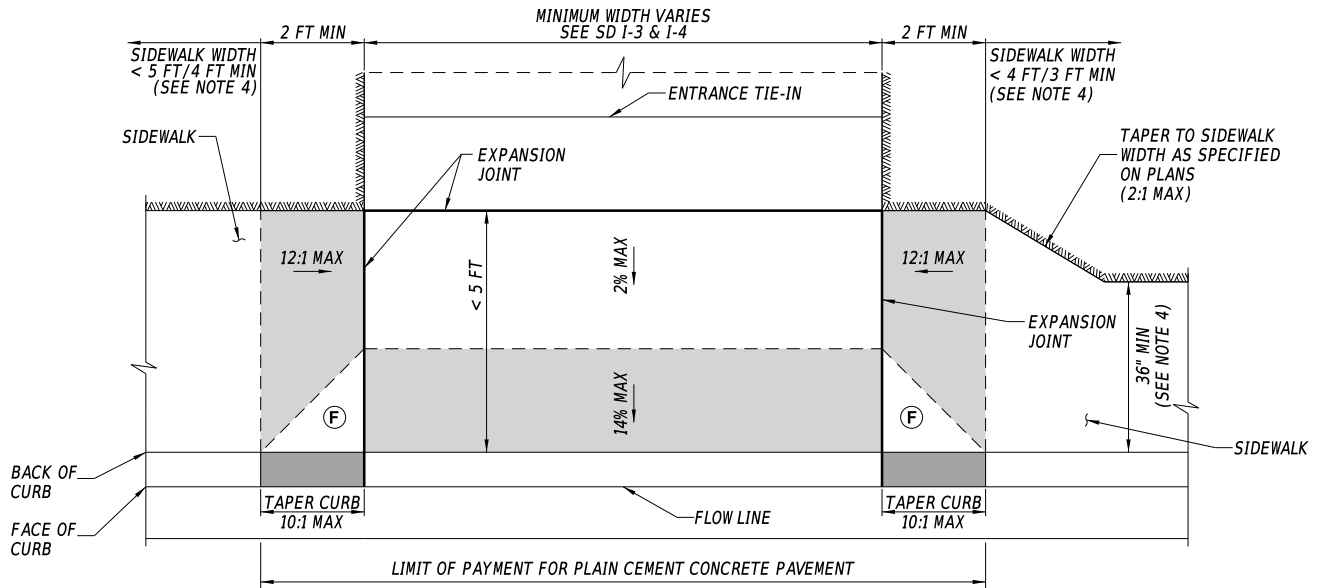

PLAN

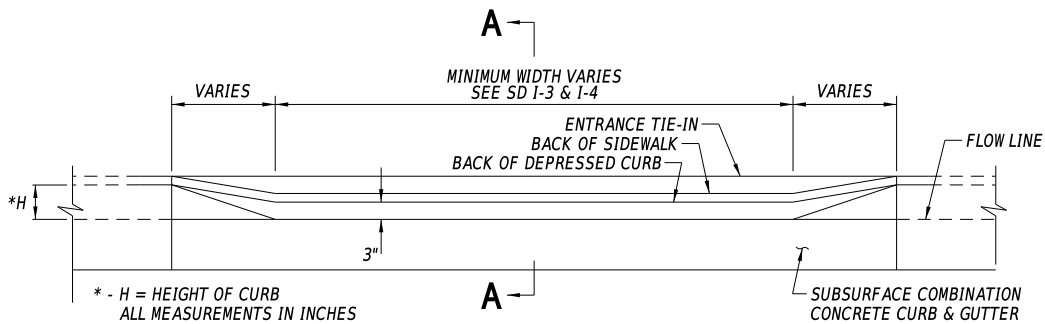

ELEVATION

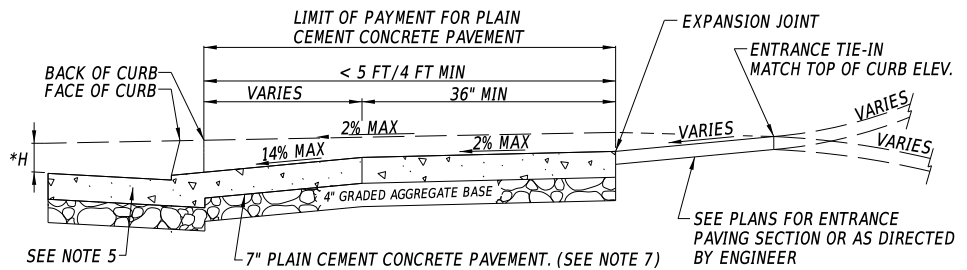
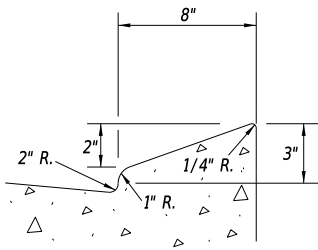

DEPRESSED CURB FOR DRIVEWAY/ENTRANCE

SECTION A-A

NOTES:

1. FOR USE IN AREAS WHERE THERE IS SIDEWALK ADJACENT TO THE BACK OF CURB OR WHERE IT IS EXPECTED THAT SIDEWALK WILL BE ADDED IN THE FUTURE.
2. WHEN AN EXISTING ENTRANCE IS LESS THAN THE MINIMUM WIDTH, A UNIFORM TAPER SHALL BE CONSTRUCTED TO TIE INTO THE EXISTING ENTRANCE AS DIRECTED BY THE ENGINEER.
3. EXPANSION JOINT MATERIAL TO BE INSTALLED IN ACCORDANCE WITH PED. FAC. STD. DETAIL PF-27 - SIDEWALK JOINTS.
4. WHERE 60" SIDEWALK CAN NOT BE PROVIDED, 48" MIN. MAY BE USED WHERE PASSING ZONES ARE PROVIDED IN ACCORDANCE WITH STD. DETAIL PF-26 - SIDEWALK PASSING ZONES. 36" MIN SIDEWALK WITH PASSING ZONES ONLY ON ALTERATIONS WITH COUNTY APPROVAL.
5. CURB AND COMBINATION CURB AND GUTTER SHALL BE DEPRESSED AS SHOWN ABOVE. PAYMENT FOR DEPRESSING THE CURB SHALL BE INCIDENTAL TO THE PRICE OF THE SPECIFIED CURB.
6. TRANSITION PANELS TO TIE INTO EXISTING SIDEWALK SHALL BE INSTALLED IN ACCORDANCE WITH PED. FAC. STD. DETAIL PF-28 - SIDEWALK TRANSITION PANEL

LEGEND	
	LANDING/TURNING SPACE SEE ADA NOTES C-2
	RAMP SURFACE SEE ADA NOTES C-1
	TAPERED CURB SEE ADA NOTES C-3
	DETECTABLE WARNING SURFACE SEE ADA NOTES D-1
	RAMP FLARE SEE ADA NOTES C-3

ANNE ARUNDEL COUNTY DEPARTMENT OF PUBLIC WORKS	APPROVED	STANDARD ROADWAY AND SITE IMPROVEMENT DETAILS	REVISED	1 / 5C
	DATE:		ADA DRIVEWAY/ENTRANCE <5 FT APRON - NO BUFFER	
	CHIEF ENGINEER			
	DESIGN ENGINEER			