

NOTE:

1. ALL BRACKETS SHALL BE FABRICATED FROM 3/8" CARBON STEEL BAR STOCK A36.
2. ALL WELDS TO BE 3/8" AND GROUND SMOOTH TO CONFORM WITH NACE RP 01-78 CONDITION D.
3. 1/2" HOLE TO BE DRILLED IN THE CENTER OF BRACKET END FOR FUTURE MOUNTING OF COAX CABLE SUPPORTS. HOLES TO BE DRILLED PRIOR TO COATING APPLICATION AND SURFACE PREPARATION.

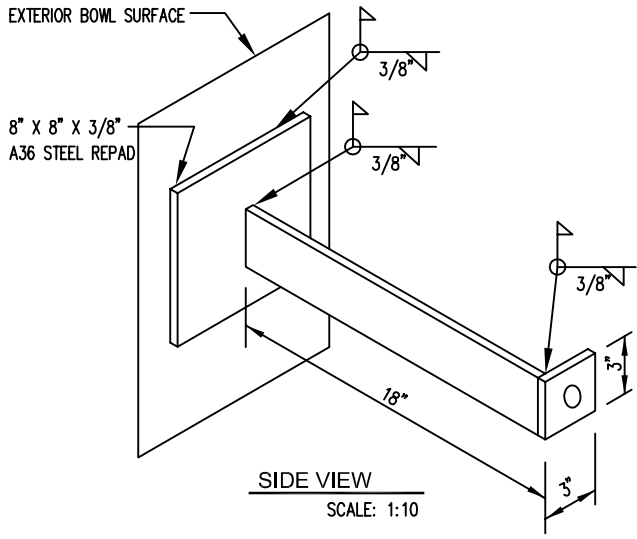

NOTE:

TABS WELDED ONTO LEGS DO NOT REQUIRE A 8" x 8" x 3/8" RE-PAD. ALL TABS TO BE WELDED ONTO BOWL OF WATER TANK SHALL HAVE THE 8" x 8" x 3/8" RE-PAD ATTACHED WITH FULL CIRCUMFERENTIAL FILLET WELDS.

Rev.	Date			LEG ANTENNA CABLE SUPPORT BRACKETS	
		DATANET 11416 REISTERSTOWN RD OWINGS MILLS, MD 21117		Date 09/04/07	Dwn. SC
				Fig. 10 OF 15	Chk. AS